

Каталог запасных частей КПП ZF S5-42 1307 050 094 (S542, 5S-42, 5S42)



Spare Parts Catalog

S 5-42 (Current date: 11.12.2012)

Material number: 1307.050.094

ZF Friedrichshafen AG
Hauptverwaltung
80038 Friedrichshafen
Deutschland
Telefon: +49 7541 77-0
Telefax: +49 7541 77-908000
www.zf.com

zuständiges Werk:
Friedrichshafen

Notes relating to the spare parts catalog

Setup of the spare parts catalog

- Cover sheet
- Technical Cover (only in SDM print)
- Overview of figures
- Figure
- Associated parts list
- Next figure
- Associated parts list
- ...

Figure and parts list



Overview of figures

Bildtafel Figure	Sachnummer Product number	Benennung (Description)	Technische Info Technical info	Description (Benennung)	Menge Quantity	Einheit Unit
068.08.17	1316.170.001	AUSLEGER	WL	SHIFT TURRET	1	Stk
068.08.06	1316.170.031	DECKEL	WL*H-H *VM	COVER	1	Stk
068.08.14	1316.170.808	DECKEL	WL*AUSL+GEH*H-H*HF160N	COVER	1	Stk
08	1316.170.441	ANSCHLUSSTEILE	WL*NG-VORB*RG-SCHL*168N *BAJONETT	CONNECTING PARTS	1	Stk

The "gap" indicates that there is no separate graphics panel (poster) for this assembly
The parts of this assembly are shown with the same mid-section number on the figure

1 Positions and subpositions

Pos.	Sachnummer Product number	Benennung (Description)	Technische Info Technical info	Description (Benennung)	Menge Quantity	Einheit Unit
0370	1315.201.054	RUECKLAUFBOLZEN	KPL.16S151*SG*L= 79	REV.IDLER SHAFT	1	Stk
/0120	0631.329.293	SPANNSTIFT		SLOT. PIN	1	Stk

Positions marked with "/" are the individual items of a completion
For example: Position 0370 contains a centering pin with the position /0120

2 Combinations with standardized parts

Pos.	Sachnummer Product number	Benennung (Description)	Technische Info Technical info	Description (Benennung)	Menge Quantity	Einheit Unit
0630		VERSCHL.SCHR.		SCREW PLUG	1	Stk
	0636.302.067	VERSCHL.SCHR.		SCREW PLUG	1	Stk
	0634.801.249	DICHTRING	A 26 X 31	SEALING RING	1	Stk

The parts list shows the components included in the combination of standardized parts

3 Depiction of position/item number on the figure and in the parts list

01.620 - on the figure 01 relates to the assembly in which the position is included. Due to program-related reasons, it is shown on the figure.

0620 - in the parts list

Pos.	Sachnummer Product number	Benennung (Description)	Technische Info Technical info	Description (Benennung)	Menge Quantity	Einheit Unit
0620	0732.040.736	DRUCKFEDER		COMPRESSION SPRING	1	Stk

4 *-Positions

Positions marked with an * are optional i.e. inclusion in the parts list is not mandatory.
The following note is shown on the figure

je nach Stücklistenausführung
depending on spec. number
*
suivant la nomenclature
secondo la distinta base

5 Parts, dotted display

Parts with dotted display on the figure are only used for orientation of other parts



Pos.	Information	Amendment number
001	Use case -----	
002	Customer MAN Nutzfahrzeuge	
003	City Muenchen	
004	DUNS 31-794-2514	
005	Vehicle / Apparatus -----	
006	Sales Name L2000	
007	Manufacturer MAN Nutzfahrzeuge	
008	Engineering Name	
009	Product Use TRUCK	
010	Vehicle/Hardware Type ROAD TRACTOR	
011	SOP	
012	Engine	
013	Sales Designation	
014	Manufacturer MAN	
015	Eng.Displ.	
016	Cylinder	
017	Nom. power 118 kW	
018	RPM at nom. power 2400 1/min	
019	Nom. torque 580 Nm	
020	RPM at nom. torque 1600 1/min	
021	Classification use case -----	
022	APPROVAL NOTE 1 ERSTEINBAU*UEBERPRUEFUNG ERFORDERLICH	
026	DESIGNATION, CLUTCH MFZ330	
027	MANUFACTURER, CLUTCH ZF-SACHS	
032	DYNAMIC TYRE RADIUS 416 mm	
033	REAR AXLE RATIO 3.45	
037	PERMISS.GROSS VEHICLE WEIGHT 11 t	
038	PERMISS.GROSS COMBIN.WEIGHT 17 t	
043	Product description -----	
044	INSTALLATION POS TRANSMISSION VERTICAL	
045	TRANSMISSION ATTACHMENT FLANGE-MOUNTED	
046	RATIO, BOTTOM GEAR 5.72	



Pos.	Information	Amendment number
047	RATIO, TOP GEAR .76	
048	SET OF RATIOS SG	
049	RATIO, 1ST GEAR 5.72	
050	RATIO, 2ND GEAR 2.94	
051	RATIO, 3RD GEAR 1.61	
052	RATIO, 4TH GEAR 1	
053	RATIO, 5TH GEAR .76	
054	RATIO, 1ST GEAR REVERSE 5.24	
055	DESIGN, SHIFT SYSTEM TURNING SHAFT	
056	POSITION, GEAR SHIFT SYSTEM LEFT HAND	
058	DESIGN, SEPARATING CLUTCH FULL-SYNCHRONIZED	
059	REFERENCE LENGTH INPUT SHAFT 78 mm	
060	STANDARD TYPE INPUT SHAFT SAE	
061	NUMBER OF WEDGES INPUT SHAFT 10	
064	VERSION OF INPUT SHAFT FORM C	
065	NOMINAL DIAMETER INPUT SHAFT 1.5 in	
079	HINWEIS ZU AUSRUECKLAGERFL CENTRAL RELEASE	
082	DESIGN BEARING OUTPUT STANDARD SUSPENSION	
083	OUTER DIA. OUTPUT FLANGE RA 120 mm	
085	NO.OF BORES OUTPUT FLANGE HA1 4	
086	BORE DIA. OUTPUT FLANGE RA 11 mm	
089	REF. LENGTH OUTPUT FLANGE RA 619 mm	
093	DIMENSION SHIFT TURRET DIST. 240 mm	
094	MEAS. LOC. SHIFT TURRET DIST. SHIFT LEVER OUTSIDE EDGE	
097	RADIUS 1 SHIFT LEVER 105 mm	
105	LEVER POSITION SHIFTING OUTPUT C	
112	GEAR SHIFT LEVER ANGLE EPSILON 24 GRAD	
116	SELECTION PATTERN VARIANT INSTALLATION DRAWING	
119	SWITCH, REVERSE GEAR y	
120	DESIGN, RG (REV.GEAR) SWITCH CLOSING	
121	NOTE ON SWITCH, REVERSE GEAR GEAR SHIFT RAIL	
164	NO PULSES PULSE SENSOR TM H70 6 IMP/U	



Pos.	Information	Amendment number
168	NOTE ASS. POS PULSE SENSOR H70 PREPARED	
198	OIL CAPACITY, GEARBOX 3.2 dm3	
201	OIL GRADE PERMISSIBLE ACC. TO TE-ML02	
203	COLOR NOT	
207	CODING OUTER CONSERVATION KA1	
208	CODING INNER CONSERVATION KI1	
209	SCOPE OUTER CONSERVATION T	
210	CONSERVATION SPECIFICATION ZFN 916	
211	Documents -----	
212	SCHALTGETRIEBE Drawing 1307.050.701	
213	SCHALTGETRIEBE Drawing 1307.600.115	
214	Alias ID -----	
215	MAN Nutzfahrzeuge 81.32002-6924	

Assembly group overview

Material number: 1307.050.094

S 5-42 (Current date: 11.12.2012) /

Page 1 from 1



Graphics	Pos.	Material number	Name	Quantity	Amend. no.	Techn. Info.
067.01.12-1	110	1307.101.118	GEARBOX HOUSING	1		
067.02.07-1	130	1307.102.053	INPUT SHAFT	1		
067.03.01-1	160	1307.103.021	LAYSHAFT	1		
067.04.04-1	200	1307.104.201	MAIN SHAFT	1		
067.04.82-1	210	1307.104.803	MAIN SHAFT	1		
067.05.01-1	220	1307.105.002	RETURN	1		
067.06.05-1	230	1307.106.046	GEAR SHIFT SYSTEM	1		
067.06.40-1	238	1307.106.422	CONNECTING PARTS	1		
067.07.01-1	280	1307.107.800	GEAR SHIFT HOUSING	1		
067.07.01-1	900	1307.107.008	GEAR SHIFT HOUSING	1		
067.07.01-1	910	1307.107.022	GEAR SHIFT SHAFT	1		

Plant

Page 1 from 1

Material number: 1307.050.094

Plant: 067.01.12-1

Material-assembly-group-no: 1307.101.118

S 5-42 (Current date: 11.12.2012) /

GEARBOX HOUSING



Bildtafel:
Figure: 067.01.12
Figure:
Figura:

je nach Stücklistenausführung
depending on spec. number
* suivant la nomenclature
secondo la distinta base

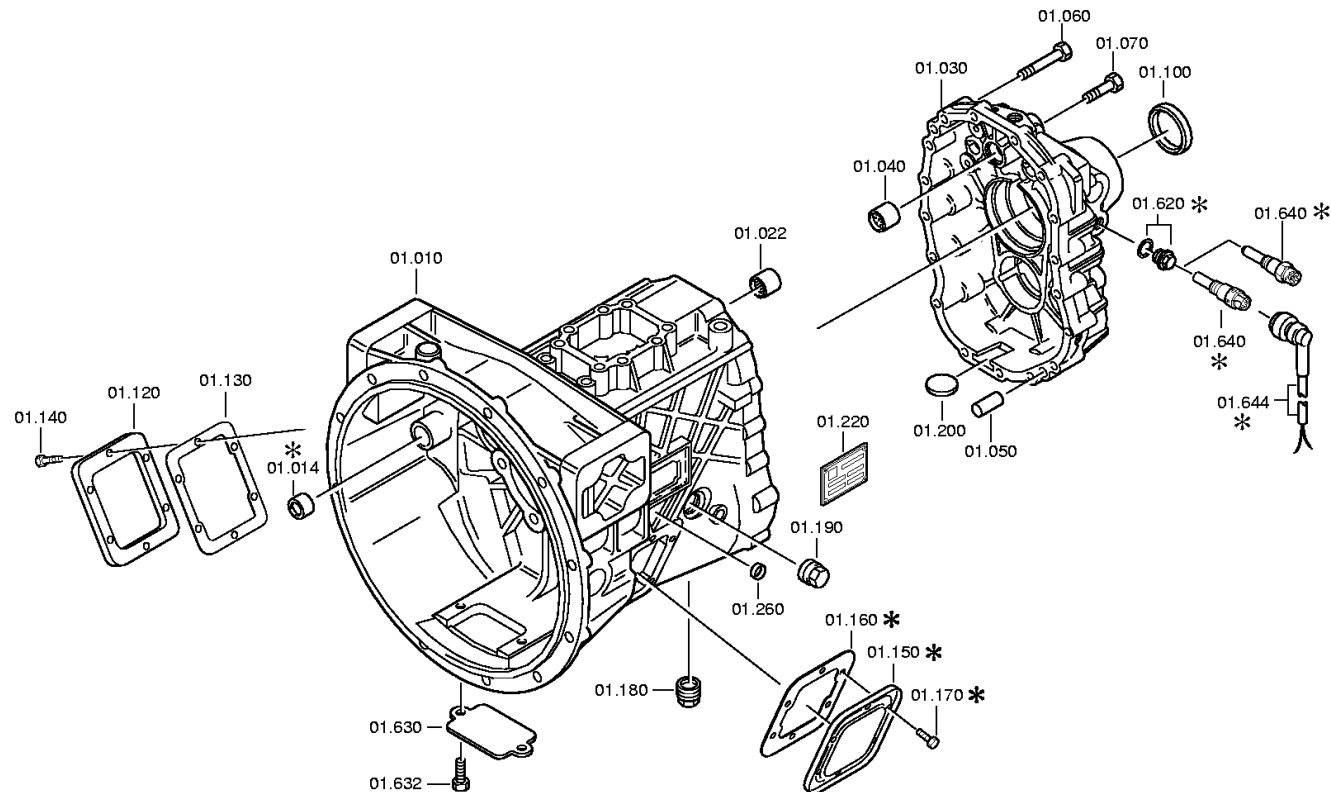

Plant

Page 1 from 1

Material number: 1307.050.094

Plant: 067.02.07-1

Material-assembly-group-no: 1307.102.053

S 5-42 (Current date: 11.12.2012) /

INPUT SHAFT

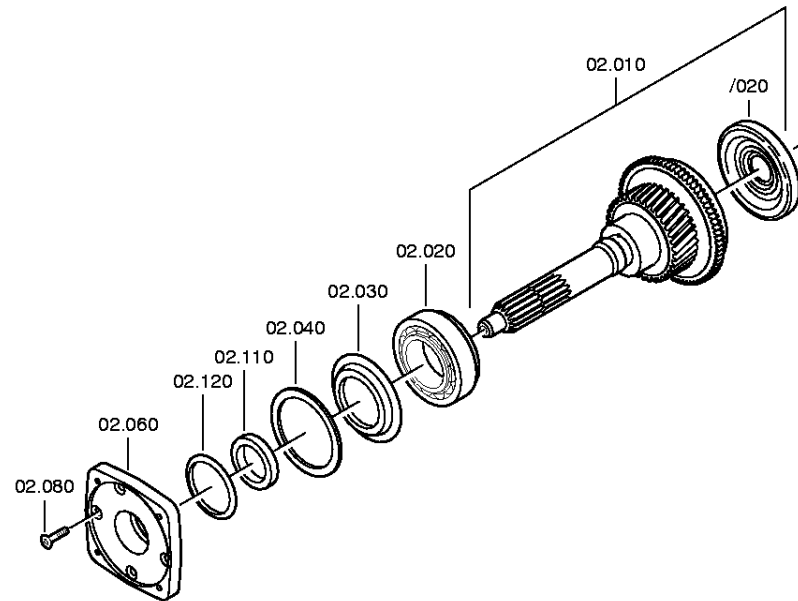

Plant

Page 1 from 1

Material number: 1307.050.094

Plant: 067.03.01-1

Material-assembly-group-no: 1307.103.021

S 5-42 (Current date: 11.12.2012) /

LAYSHAFT

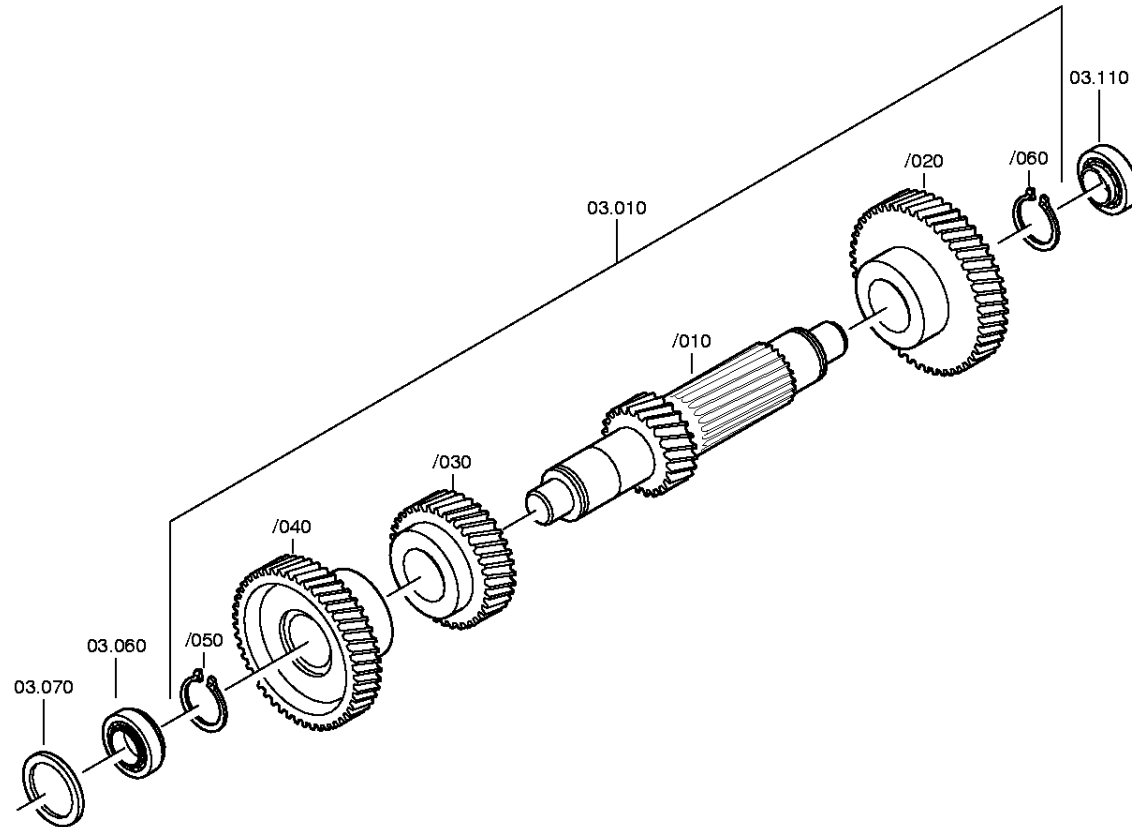

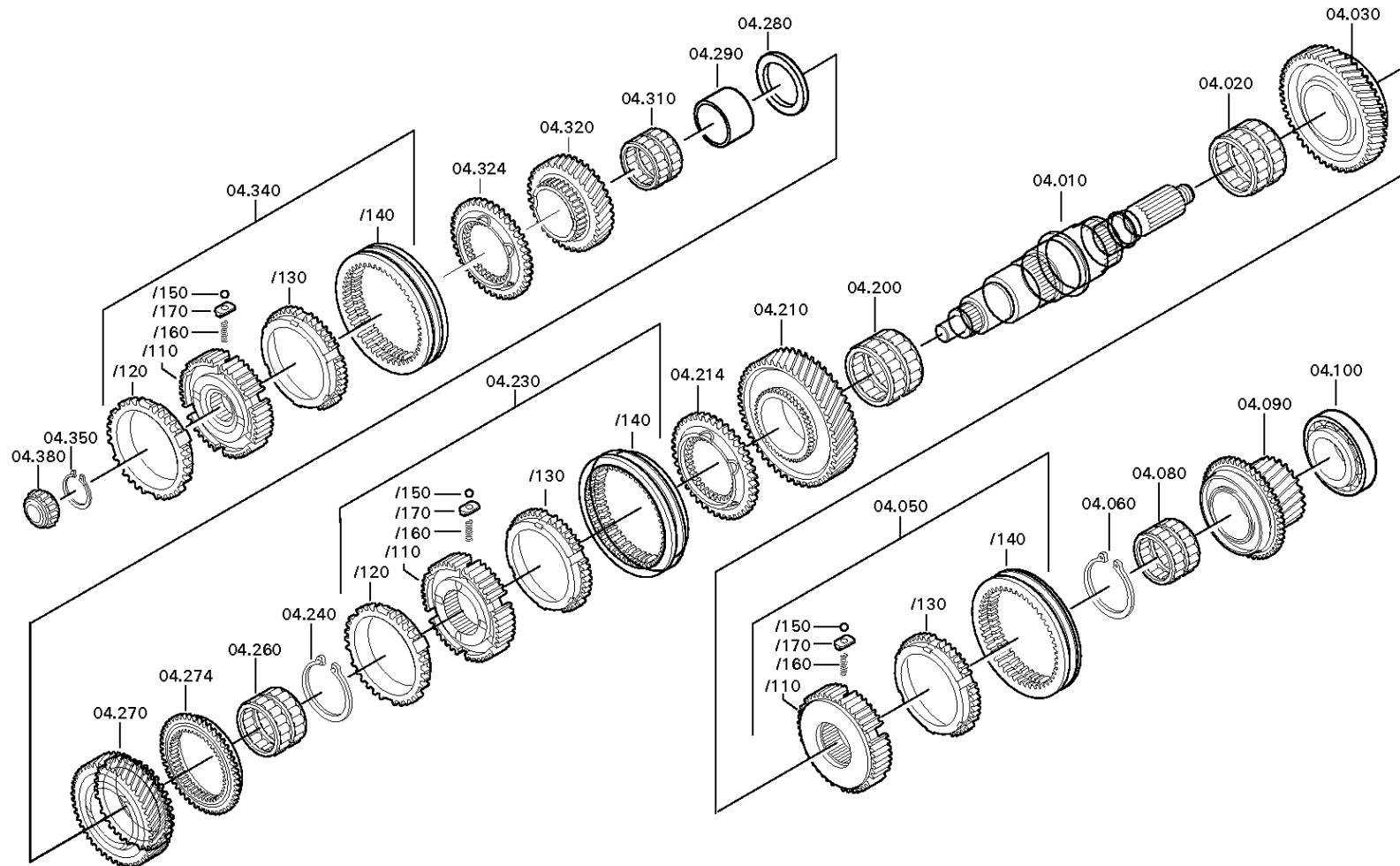

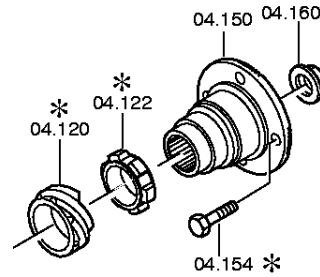

Plant

Page 1 from 1

Material number: 1307.050.094

Plant: 067.05.01-1

Material-assembly-group-no: 1307.105.002

S 5-42 (Current date: 11.12.2012) /

RETURN

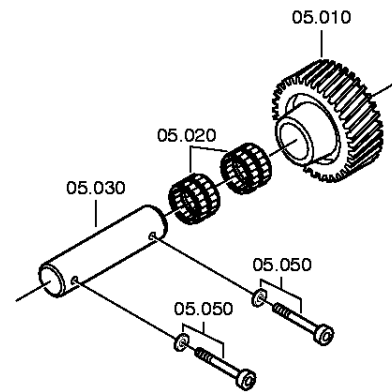

Plant

Page 1 from 2

Material number: 1307.050.094
Plant: 067.06.05-1
GEAR SHIFT SYSTEM

S 5-42 (Current date: 11.12.2012) /
GEAR SHIFT SYSTEM

