



Spare Parts Catalog

2 HL 270

Material number: 4143.020.164

Current date: 23.09.2021

ZF Friedrichshafen AG
Hauptverwaltung
80038 Friedrichshafen
Deutschland

Telefon: +49 7541 77-0

Telefax: +49 7541 77-908000

www.zf.com

zuständiges Werk:
Passau

Notes relating to the spare parts catalog

Setup of the spare parts catalog

- Cover sheet
- Technical Cover (only in SDM print)
- Overview of figures
- Figure
- Associated parts list
- Next figure
- Associated parts list
- ...

Figure and parts list



Overview of figures

Bildtafel Figure	Sachnummer Product number	Benennung (Description)	Technische Info Technical info	Description (Benennung)	Menge Quantity	Einheit Unit
068.08.17	1316.170.001	AUSLEGER	WL	SHIFT TURRET	1	Stk
068.08.06	1316.170.031	DECKEL	WL*H-H *VM	COVER	1	Stk
068.08.14	1316.170.808	DECKEL	WL*AUSL+GEH*H-H*HF160N	COVER	1	Stk
08	1316.170.441	ANSCHLUSSTEILE	WL*NG-VORB*RG-SCHL*168N *BAJONETT	CONNECTING PARTS	1	Stk

The "gap" indicates that there is no separate graphics panel (poster) for this assembly
The parts of this assembly are shown with the same mid-section number on the figure

1 Positions and subpositions

Pos.	Sachnummer Product number	Benennung (Description)	Technische Info Technical info	Description (Benennung)	Menge Quantity	Einheit Unit
0370	1315.201.054	RUECKLAUFBOLZEN	KPL.16S151*SG*L= 79	REV.IDLER SHAFT	1	Stk
/0120	0631.329.293	SPANNSTIFT		SLOT. PIN	1	Stk

Positions marked with "/" are the individual items of a completion
For example: Position 0370 contains a centering pin with the position /0120

2 Combinations with standardized parts

Pos.	Sachnummer Product number	Benennung (Description)	Technische Info Technical info	Description (Benennung)	Menge Quantity	Einheit Unit
0630		VERSCHL.SCHR.		SCREW PLUG	1	Stk
	0636.302.067	VERSCHL.SCHR.		SCREW PLUG	1	Stk
	0634.801.249	DICHTRING	A 26 X 31	SEALING RING	1	Stk

The parts list shows the components included in the combination of standardized parts

3 Depiction of position/item number on the figure and in the parts list

01.620 - on the figure 01 relates to the assembly in which the position is included. Due to program-related reasons, it is shown on the figure.

0620 - in the parts list

Pos.	Sachnummer Product number	Benennung (Description)	Technische Info Technical info	Description (Benennung)	Menge Quantity	Einheit Unit
0620	0732.040.736	DRUCKFEDER		COMPRESSION SPRING	1	Stk

4 *-Positions

Positions marked with an * are optional i.e. inclusion in the parts list is not mandatory.
The following note is shown on the figure

je nach Stücklistenausführung
depending on spec. number
*
suivant la nomenclature
secondo la distinta base

5 Parts, dotted display

Parts with dotted display on the figure are only used for orientation of other parts

Technical Cover

Page 1 from 3

Material number: 4143.020.164



2 HL 270 /

Pos.	Information	Amendment number
	CUSTOMER-VEHICLE DATA 1: -----	
	CUSTOMER: TVEX	
	VEHICLE DESIGNATION: EK-20	
	ENGINE POWER: 114,0 KW	
	WEIGHT EMPTY: 20,000 TO	
	TIRES: 10.00-20	
	TIRE RADIUS: 0,506 M	
	HYDRAULIC PUMP: A8VLAH	
	MANUFACTURER: REXROTH	
	HYDR. PUMP POWER: 88,8 KW	
	OIL FLOW: 200,0 CDM	
	HYDROMOTOR: A6VM 140	
	MANUFACTURER: REXROTH	
	DIFFERENTIAL PRESSURE: 320 BAR	
	FRONT AXLE: MS-E 3060	
	REAR AXLE: MT-E 3060	
	AXLE RATIO: 18,66	
	PERFORMANCE CALC.: 4143 701 599	
	BRAKE CALCULATION: 4143 709 384	
	VEHICLE DESIGNATION: EK 18-90 SCRAP	
	ENGINE POWER: 90,0 KW	
	WEIGHT EMPTY: 21,400 TO	
	TIRES: 10.00-20	
	TIRE RADIUS: 0,506 M	
	HYDRAULIC PUMP: A11VO 130	
	MANUFACTURER: REXROTH	
	HYDR. PUMP POWER: 63,6 KW	
	OIL FLOW: 210,2 CDM	
	HYDROMOTOR: A6VM 140	
	MANUFACTURER: REXROTH	
	DIFFERENTIAL PRESSURE: 320 BAR	
	FRONT AXLE: MS-E 3070	
	REAR AXLE: MT-E 3070	

Technical Cover

Page 2 from 3

Material number: 4143.020.164



2 HL 270 /

Pos.	Information	Amendment number
	AXLE RATIO: 18,66	
	PERFORMANCE CALC.: 4143 701 652	
	BRAKE CALCULATION: 4143 709 384	
	VEHICLE DESIGNATION: TVEX 180 I	
	ENGINE POWER: 90,0 KW	
	WEIGHT EMPTY: 21,400 TO	
	TIRES: 10.00-20	
	TIRE RADIUS: 0,506 M	
	HYDRAULIC PUMP: A11VO 130	
	MANUFACTURER: REXROTH	
	HYDR. PUMP POWER: 63,6 KW	
	OIL FLOW: 210,2 CDM	
	HYDROMOTOR: A6VM 150	
	MANUFACTURER: REXROTH	
	DIFFERENTIAL PRESSURE: 320 BAR	
	FRONT AXLE: MS-E 3070	
	REAR AXLE: MT-E 3070	
	AXLE RATIO: 18,66	
	PERFORMANCE CALC.: 4143 701 772	
	BRAKE CALCULATION: 4143 709 512	
	PRODUCT DESCRIPTION: ZF- POWERSHIFT TRANSMISSION HL	
	TRANSMISSION TYPE: 2 HL 270	
	DROP CENTER DISTANCE: 185 MM	
	TRANSMISSION INSTALLATION: REMOTE MOUNT	
	INSTALLATION POSITION: HORIZONTAL	
	OUTPUT FLANGE: DIN 120	
	GEAR RATIO: 1ST GEAR=4,869; 2ND GEAR=1,196	
	HYDRO MOTOR SPLINE: N45 X 2 X 30 X 21 X 10H	
	CENTERING DIAMETER: 180 H7	
	VALVE BLOCK: SEPARATELY	
	VOLTAGE: 24 VOLT	
	DOWNSHIFT PROT.: HYDR. CONNECTION M18X1.5	
	SPEED SENSOR: WITHOUT	

Technical Cover

Page 3 from 3

Material number: 4143.020.164



2 HL 270 /

Pos.	Information	Amendment number
	OIL FILLING: WITH	
	GEARBOX OIL - GRADE: TE ML 07	
	OIL FILL QUANTITY CA: 2,90 L	
	TYPE PLATE: ZF- STANDARD	
	PAINTING: PRIMING	
	COLOR: BLACK RAL 9005	
	SEPARATE ORDER CUSTOMER: 0750.132.135 VALVE BLOCK: 24V	
	DOCUMENTATION: -----	
	SECTION DRAWING: 4143 020 031	
	INSTALLATION DRAWING: 4143.620.020	
	INSTALL. INSTRUCTIONS: 5872 014 002	

Assembly group overview

Page 1 from 1

Material number: 4143.020.164



2 HL 270 /

Graphics	Pos.	Material number	Name	Quantity	Amend. no.	Techn. Info.
4143125044 20	490	4143.125.044	INPUT HOUSING	1		
4143101043 00	10	4143.101.043	HOUSING	1		
4143151019 00	810	4143.151.019	MULTIDISK BRAKE	1		
4143152011 00	830	4143.152.011	COUPLING	1		
4143115017 00	290	4143.115.017	PLANETARY DRIVE	1		
4143115401 00	300	4143.115.401	PLANETARY DRIVE	1		
4143115405 00	295	4143.115.405	PLANETARY DRIVE	1		
4143103037 20	50	4143.103.037	OUTPUT	1		
4143103420 50	57	4143.103.420	OUTPUT	2		
4143142025 20	520	4143.142.025	GEAR SHIFT SENSOR	1		
4143142406 20	540	4143.142.406	GEAR SHIFT SENSOR	1		
4143142407 20	525	4143.142.407	GEAR SHIFT SENSOR	1		
4143121011 20	390	4143.121.011	OIL PIPE	1		
4143139001 00	900	4143.139.001	TYPE PLATE	1		

Plant

Page 1 from 1

Material number: 4143.020.164

Plant: 414312504420

Material-assembly-group-no: 4143.125.044



2 HL 270 /
INPUT HOUSING

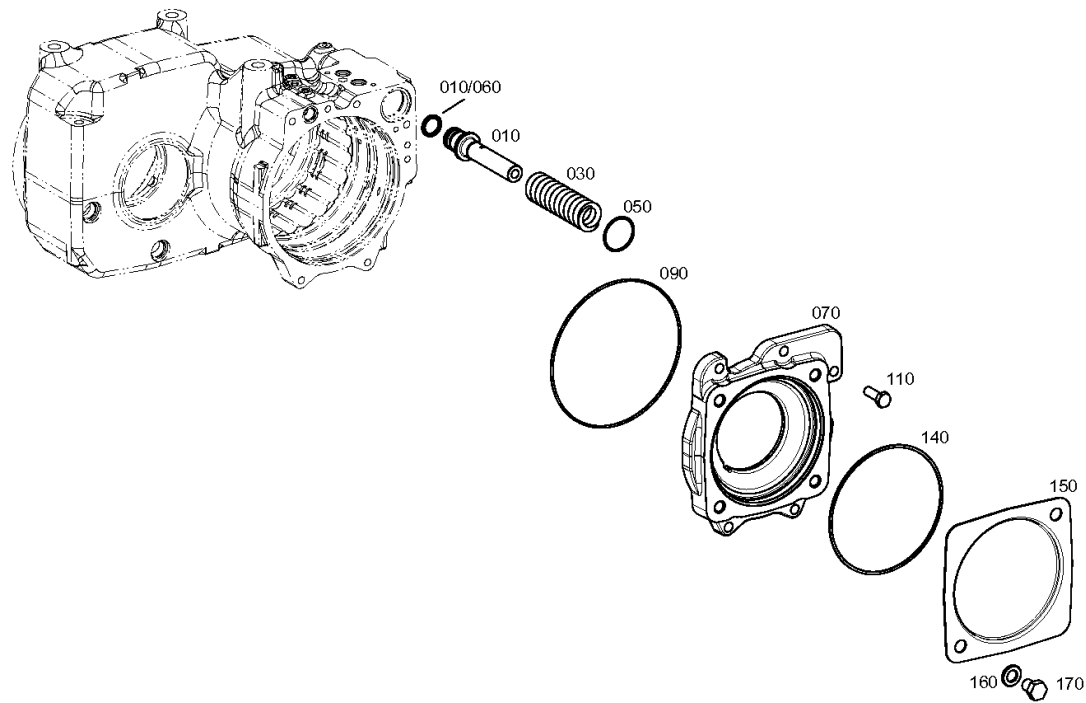

Plant

Page 1 from 2

Material number: 4143.020.164

Plant: 414310104300

Material-assembly-group-no: 4143.101.043



2 HL 270 /
HOUSING

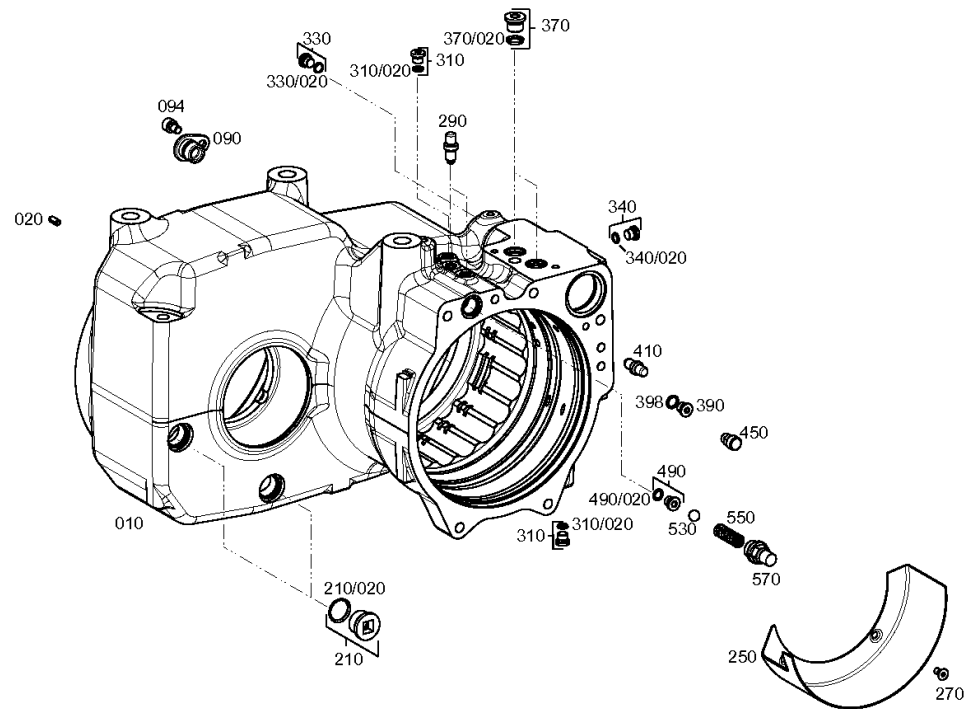

Plant

Page 2 from 2

Material number: 4143.020.164

Plant: 414310104320

Material-assembly-group-no: 4143.101.043



2 HL 270 /
HOUSING

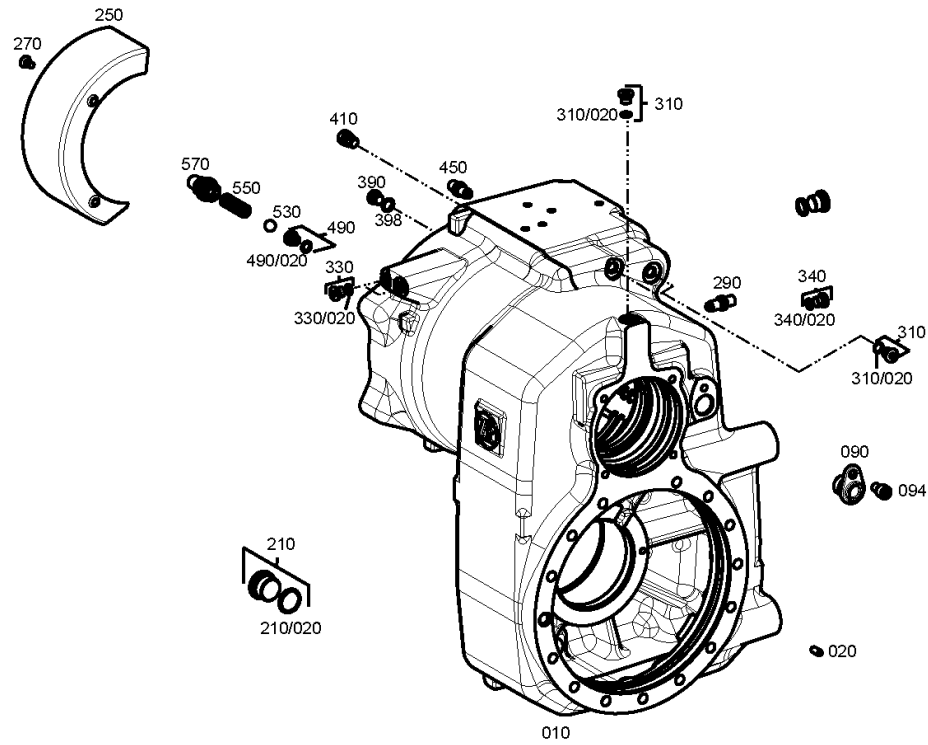

Plant

Page 1 from 2

Material number: 4143.020.164

Plant: 414315101900

Material-assembly-group-no: 4143.151.019



2 HL 270 /
MULTIDISK BRAKE

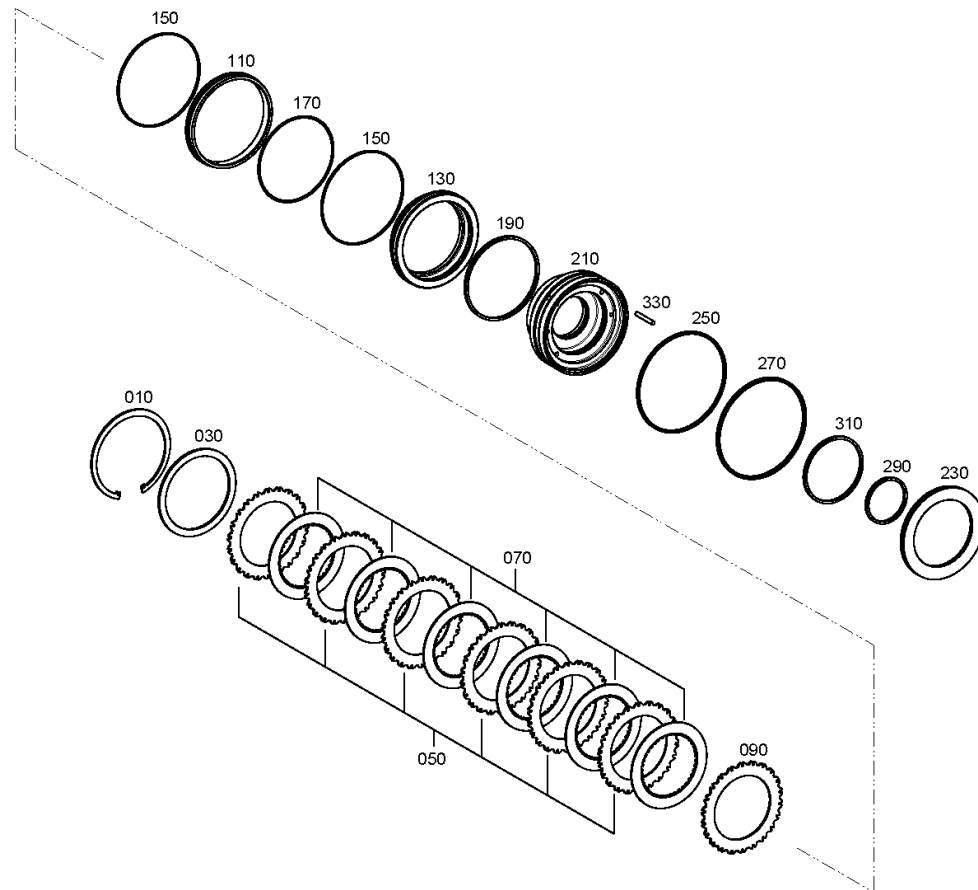

Plant

Page 2 from 2

Material number: 4143.020.164

Plant: 414315101930

Material-assembly-group-no: 4143.151.019



2 HL 270 /
MULTIDISK BRAKE

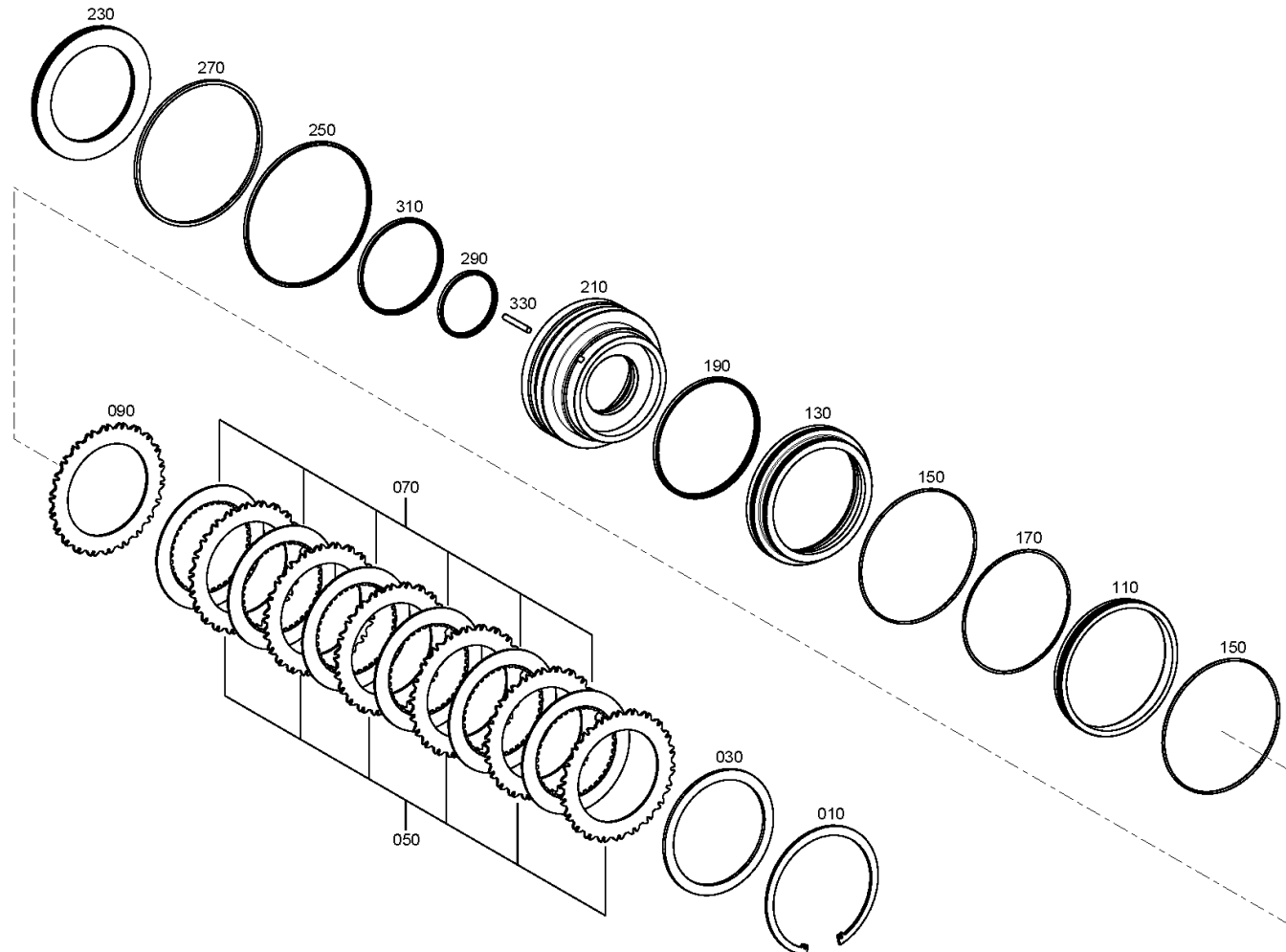

Plant

Page 1 from 1

Material number: 4143.020.164

Plant: 414315201100

Material-assembly-group-no: 4143.152.011



2 HL 270 /
COUPLING

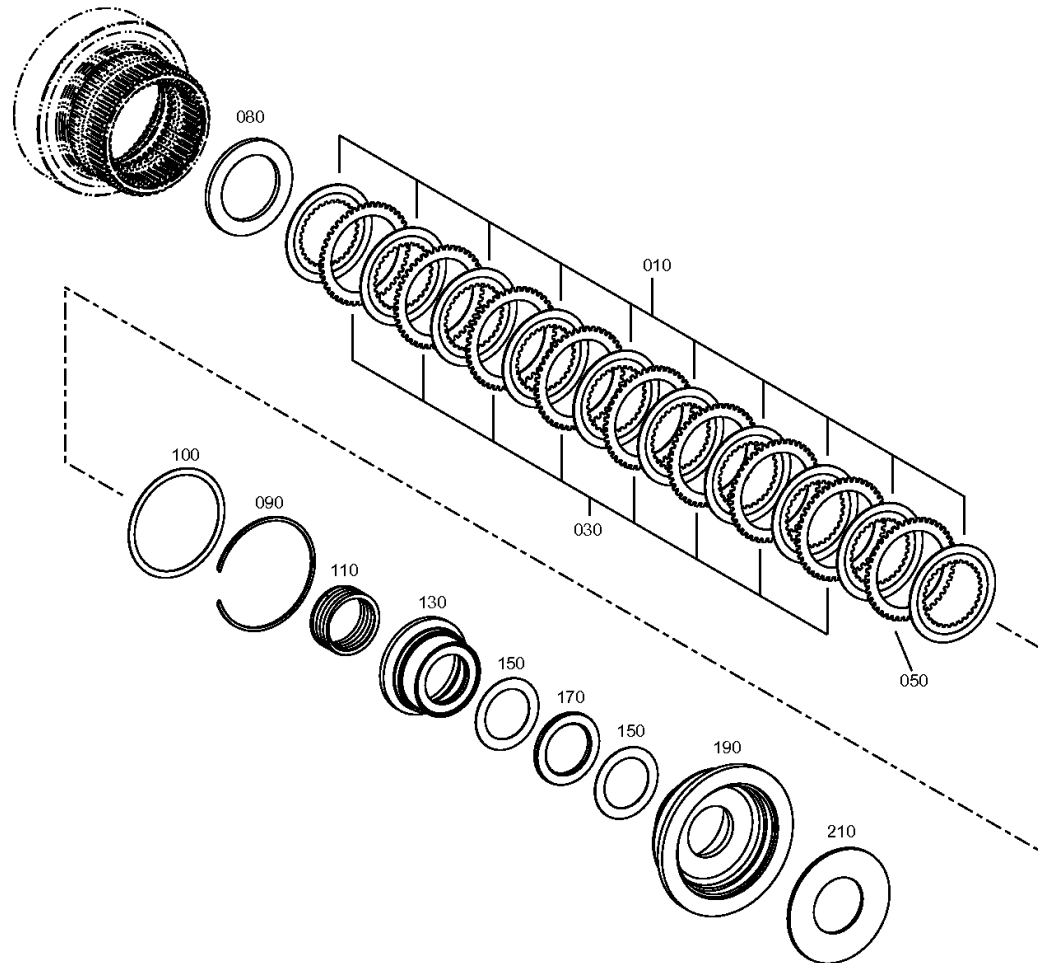

Plant

Page 1 from 1

Material number: 4143.020.164

Plant: 414311501700

Material-assembly-group-no: 4143.115.017



2 HL 270 /
PLANETARY DRIVE

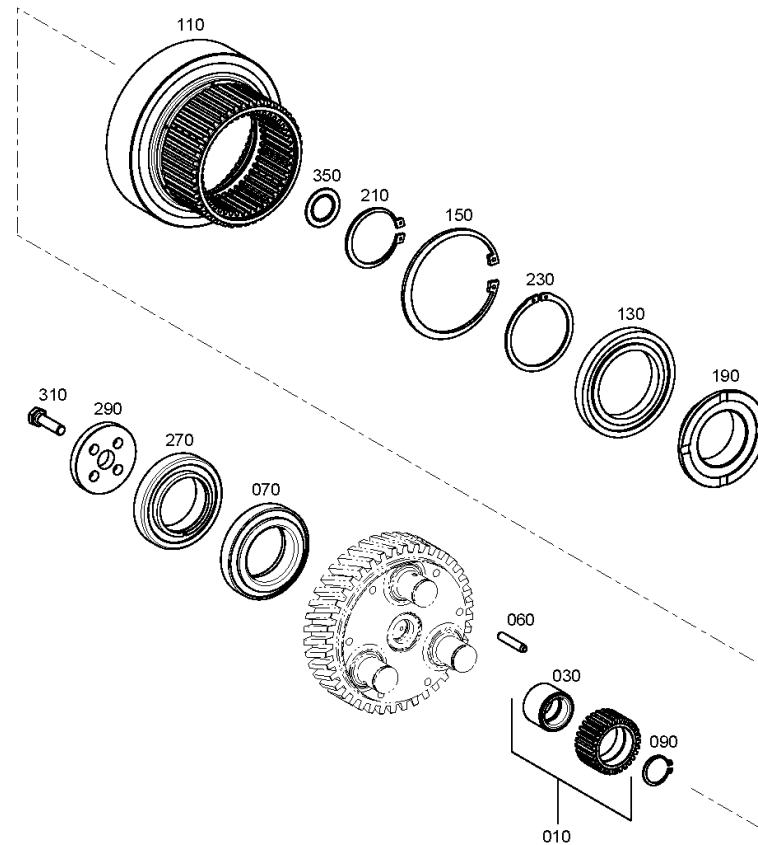

Plant

Page 1 from 1

Material number: 4143.020.164

Plant: 414311540100

Material-assembly-group-no: 4143.115.401



2 HL 270 /
PLANETARY DRIVE

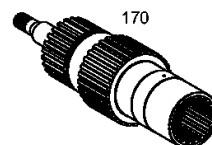

Plant

Page 1 from 1

Material number: 4143.020.164

Plant: 414311540500

Material-assembly-group-no: 4143.115.405



2 HL 270 /
PLANETARY DRIVE

050

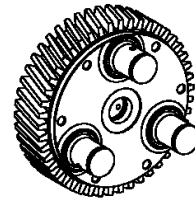

Plant

Page 1 from 1

Material number: 4143.020.164

Plant: 414310303720

Material-assembly-group-no: 4143.103.037



2 HL 270 /
OUTPUT

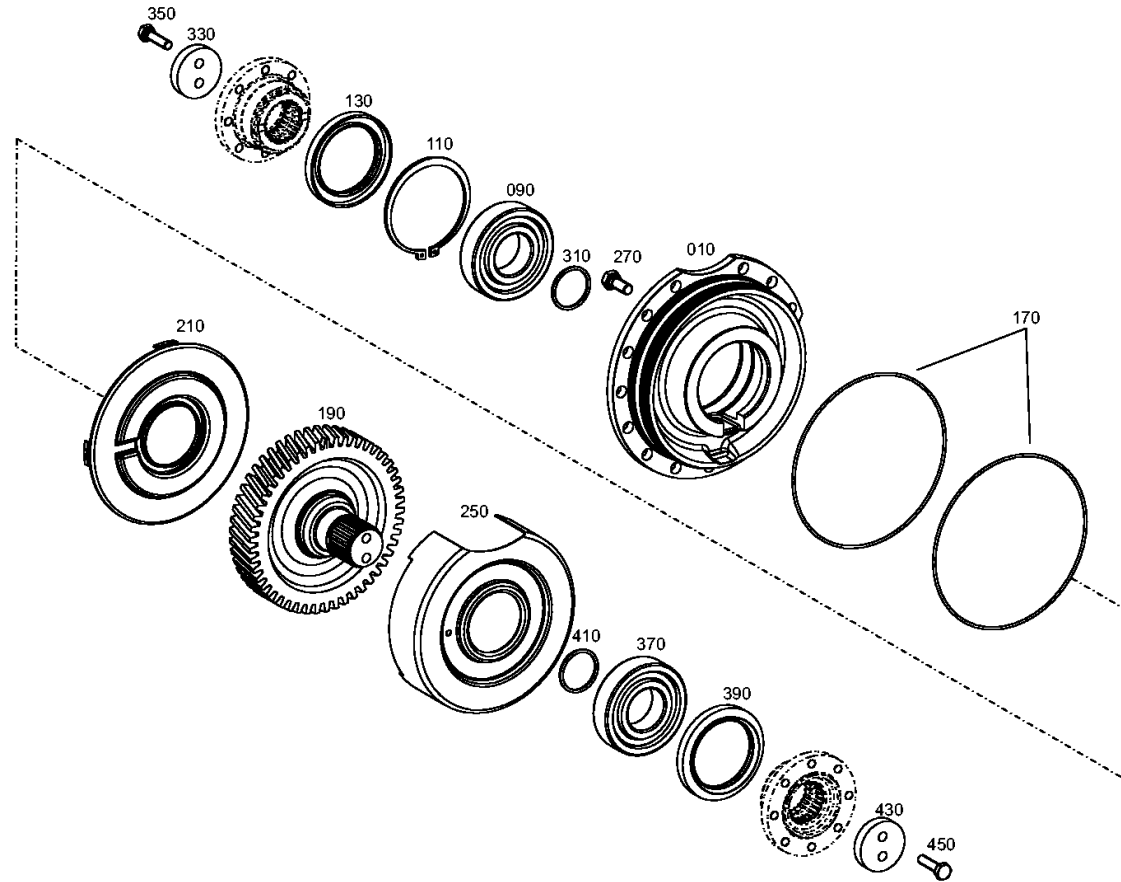

Plant

Page 1 from 1

Material number: 4143.020.164

Plant: 414310342050

Material-assembly-group-no: 4143.103.420



2 HL 270 /
OUTPUT

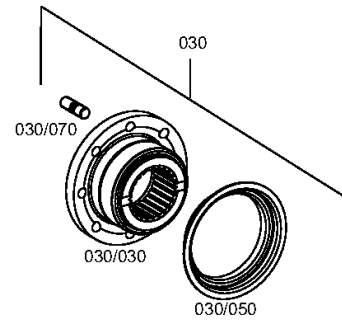

Plant

Page 1 from 1

Material number: 4143.020.164

Plant: 414314202520

Material-assembly-group-no: 4143.142.025



2 HL 270 /
GEAR SHIFT SENSOR

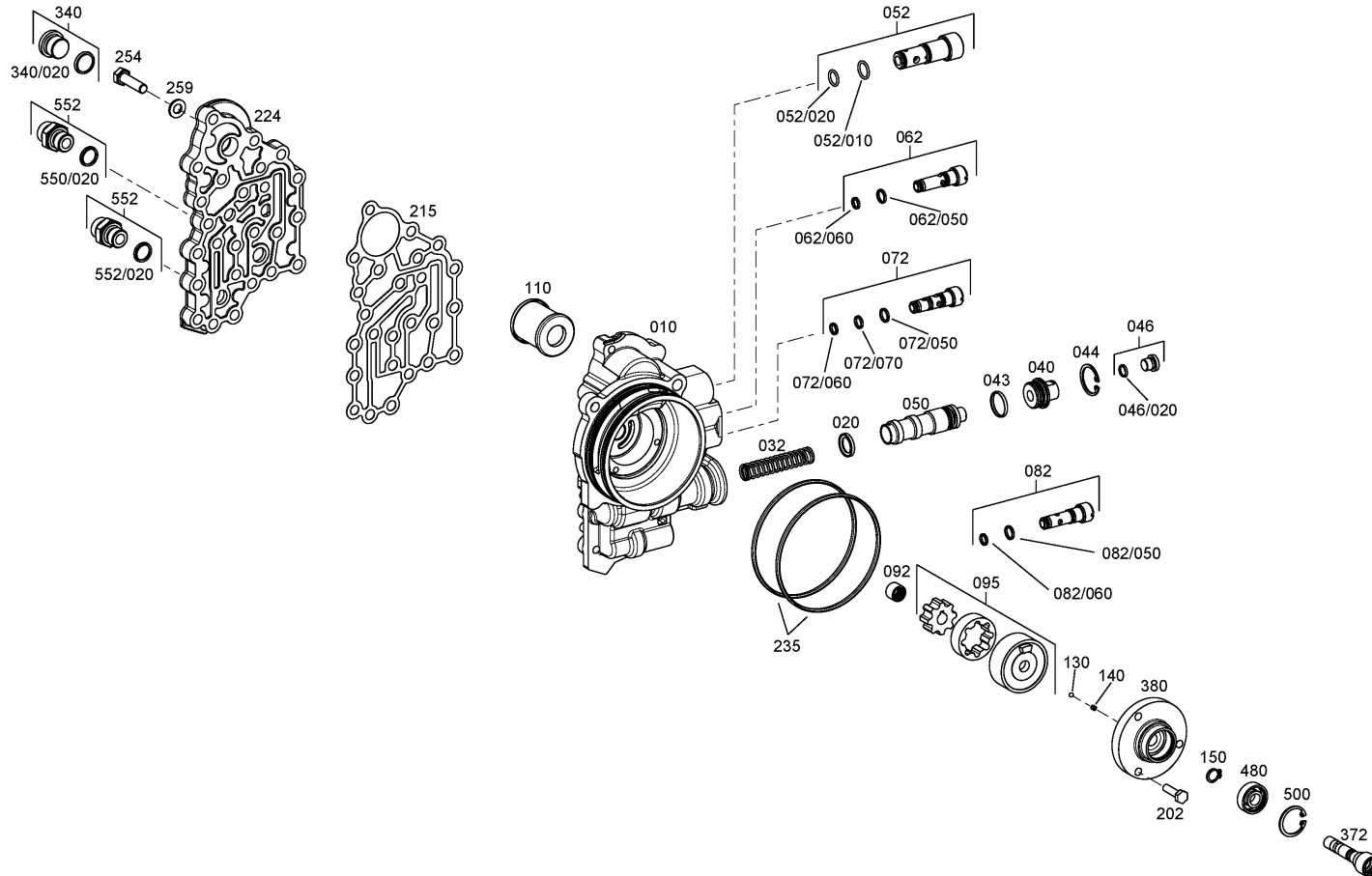

Plant

Page 1 from 1

Material number: 4143.020.164

Plant: 414314240620

Material-assembly-group-no: 4143.142.406



2 HL 270 /
GEAR SHIFT SENSOR

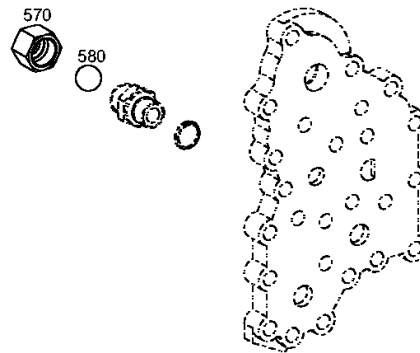

Plant

Page 1 from 1

Material number: 4143.020.164

Plant: 414314240720

Material-assembly-group-no: 4143.142.407



2 HL 270 /
GEAR SHIFT SENSOR

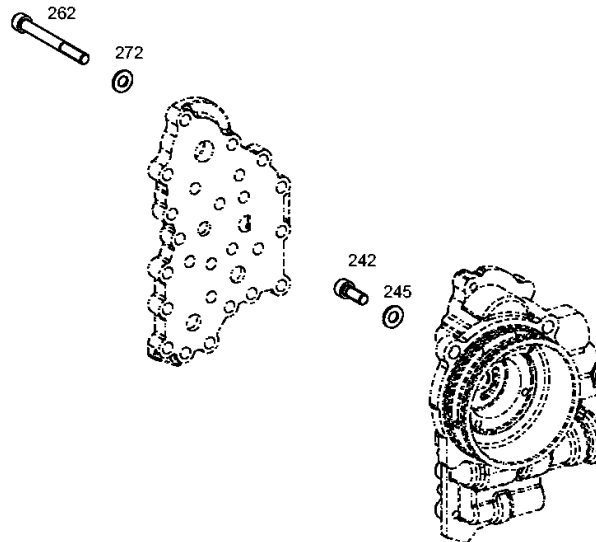

Plant

Page 1 from 1

Material number: 4143.020.164

Plant: 414312101120

Material-assembly-group-no: 4143.121.011



2 HL 270 /
OIL PIPE

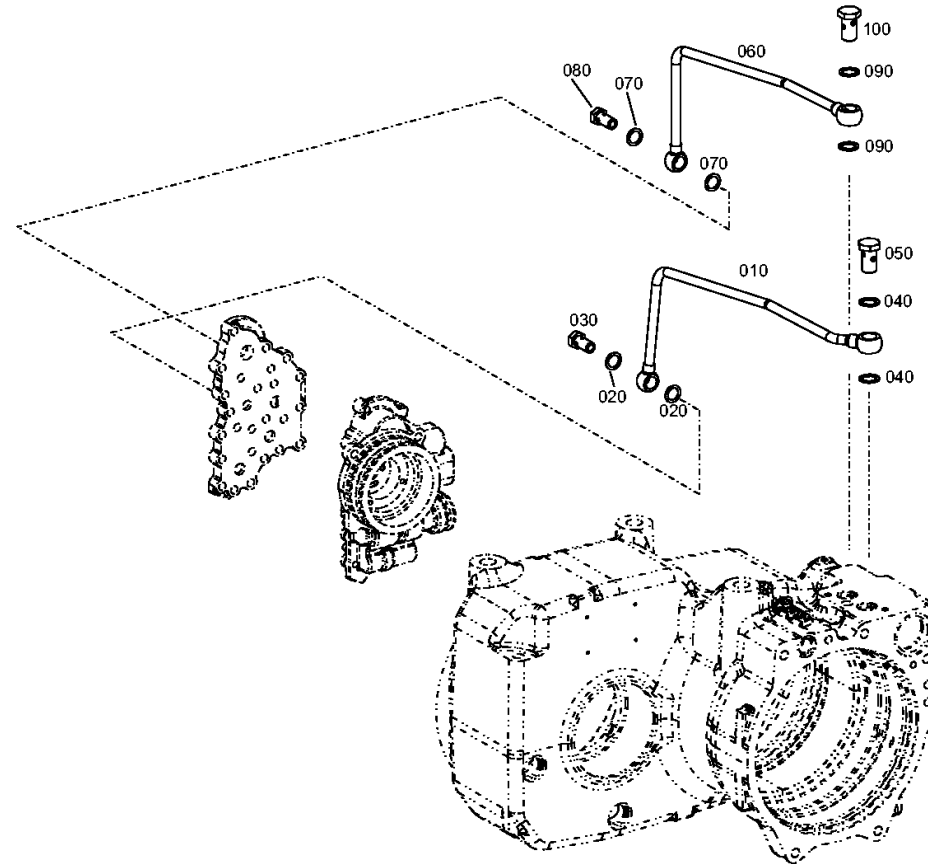

Plant

Page 1 from 1

Material number: 4143.020.164

Plant: 414313900100

Material-assembly-group-no: 4143.139.001



2 HL 270 /
TYPE PLATE



010