



Spare Parts Catalog

MT-G 3080

Material number: 4469.021.014

Current date: 21.03.2023

ZF Friedrichshafen AG
Hauptverwaltung
80038 Friedrichshafen
Deutschland

Telefon: +49 7541 77-0

Telefax: +49 7541 77-908000

www.zf.com

zuständiges Werk:
Passau

Notes relating to the spare parts catalog

Setup of the spare parts catalog

- Cover sheet
- Technical Cover (only in SDM print)
- Overview of figures
- Figure
- Associated parts list
- Next figure
- Associated parts list
- ...

Figure and parts list



Overview of figures

Bildtafel Figure	Sachnummer Product number	Benennung (Description)	Technische Info Technical info	Description (Benennung)	Menge Quantity	Einheit Unit
068.08.17	1316.170.001	AUSLEGER	WL	SHIFT TURRET	1	Stk
068.08.06	1316.170.031	DECKEL	WL*H-H *VM	COVER	1	Stk
068.08.14	1316.170.808	DECKEL	WL*AUSL+GEH*H-H*HF160N	COVER	1	Stk
08	1316.170.441	ANSCHLUSSTEILE	WL*NG-VORB*RG-SCHL*168N *BAJONETT	CONNECTING PARTS	1	Stk

The "gap" indicates that there is no separate graphics panel (poster) for this assembly
The parts of this assembly are shown with the same mid-section number on the figure

1 Positions and subpositions

Pos.	Sachnummer Product number	Benennung (Description)	Technische Info Technical info	Description (Benennung)	Menge Quantity	Einheit Unit
0370	1315.201.054	RUECKLAUFBOLZEN	KPL.16S151*SG*L= 79	REV.IDLER SHAFT	1	Stk
/0120	0631.329.293	SPANNSTIFT		SLOT. PIN	1	Stk

Positions marked with "/" are the individual items of a completion
For example: Position 0370 contains a centering pin with the position /0120

2 Combinations with standardized parts

Pos.	Sachnummer Product number	Benennung (Description)	Technische Info Technical info	Description (Benennung)	Menge Quantity	Einheit Unit
0630		VERSCHL.SCHR.		SCREW PLUG	1	Stk
	0636.302.067	VERSCHL.SCHR.		SCREW PLUG	1	Stk
	0634.801.249	DICHTRING	A 26 X 31	SEALING RING	1	Stk

The parts list shows the components included in the combination of standardized parts

3 Depiction of position/item number on the figure and in the parts list

01.620 - on the figure 01 relates to the assembly in which the position is included. Due to program-related reasons, it is shown on the figure.

0620 - in the parts list

Pos.	Sachnummer Product number	Benennung (Description)	Technische Info Technical info	Description (Benennung)	Menge Quantity	Einheit Unit
0620	0732.040.736	DRUCKFEDER		COMPRESSION SPRING	1	Stk

4 *-Positions

Positions marked with an * are optional i.e. inclusion in the parts list is not mandatory.
The following note is shown on the figure

je nach Stücklistenausführung
depending on spec. number
*
suivant la nomenclature
secondo la distinta base

5 Parts, dotted display

Parts with dotted display on the figure are only used for orientation of other parts

Technical Cover

Page 1 from 2

Material number: 4469.021.014



MT-G 3080 /

Pos.	Information	Amendment number
	KUNDENNAME: BRJANSKY ARSENAL	
	FAHRZEUGBEZEICHNUNG: GS14.03	
	REIFENGROESSE: 14.00-20	
	REIFENRADIUS DYN: 0,630 M	
	ENDGESCHWINDIGKEIT: 37 KM/H	
	FAHRZEUGBEZEICHNUNG: GS18.07	
	REIFENGROESSE: 14.00R24	
	REIFENRADIUS: 0,670 M	
	ENDGESCHWINDIGKEIT: 39,0 KM/H	
	TANDEMÜBERSETZUNG: 18,238	
	PRODUKTBESCHREIBUNG: ZF- MULTITRAC ACHSE	
	FAHRZEUGART: GRADER	
	ACHSENTYP: MT-G 3080	
	DRIVELINE SYSTEM: I ACHSE INCL. PLANETENTRIEB	
	AUSFUEHRUNG: STARR	
	ACHSANORDNUNG: HINTERACHSE	
	DREHRICHTUNG RITZEL: EDUL	
	TELLERRADLAGE: LINKS	
	SPIRALRICHTUNG: LINKS	
	ANTRIEBSFLANSCH: MECH 7 C	
	KETTENRADPROFIL: SAE DP 10/20 Z=32	
	KETTENKASTENANSCHLUß: LKR=375MM 23XM20	
	FLANSCHMASS.: 1.150 MM	
	AUFHAENGUNG: FEDERBLATT	
	BEFESTIGUNGSMASSE/MM: 850X400/500ASYM 8 X D=26	
	QUERDIFFERENTIAL: SPERRDIFFERENTIAL	
	DIFFERENTIAL TYP/GRÖßE: DHLD - 1600	
	DIFFERENTIAL- SPERRE: LASTHALTBAR	
	BETAETIGUNG: HYDRAULISCH	
	ANSCHLUSS: 7/16 -20 UNF-2B	
	BETAETIGUNGSDRUCK: 16 +- 2BAR	
	ACHSUEBERSETZUNG: 15,198	
	PLANETENTRIEB: P4, I=6,0	

Technical Cover

Page 2 from 2

Material number: 4469.021.014



MT-G 3080 /

Pos.	Information	Amendment number
	KEGELTRIEB: 2,533	
	PARKBREMSE: LAMELLENBREMSE 236X158X5	
	BREMSANSCHLUSS: 9/16 - 18 UNF 2B	
	BETAETIGUNGSDRUCK: 16 +4 BAR	
	ACHSE OELFUELLUNG: MIT	
	OELSORTE: TE ML 05 G(TITAN POWERFLUID)	
	OELSORTE ZUL.: TE ML 05 E/F/G	
	FARBE: MAISGELB RAL 1006	
	ABD. FARBFREIE FLAECHE: STANDARD GRADER	
	TYPENSCHILD: ZF- STANDARD	
	OELMENGE GESAMT CA: 22,30 L	
	DOKUMENTATION: -----	
	SCHNITTZEICHNUNG: 4469 021 007	
	EINBAUZEICHNUNG: 4469 621 005	
	EINBAURICHTLINIEN: 4472 700 021	
	PRUEFANWEISUNG: 4469 760 001	

Assembly group overview

Page 1 from 1

Material number: 4469.021.014



MT-G 3080 /

Picture	Pos.	Material number	Name	Quantity	Amend. no.	Techn. Info.
446911600700	10	4469.116.007	INPUT	1		
446911640200	20	4469.116.402	INPUT	1		
448117103100	30	4481.171.031	LIM.SLIP DIFF.	1		
446911700400	70	4469.117.004	AXLE CASING	1		
446911740100	80	4469.117.401	AXLE CASING	1		
446911900200	130	4469.119.002	OUTPUT	1		
446911940300	140	4469.119.403	OUTPUT	1		
446912100300	150	4469.121.003	MULTIDISK BRAKE	1		

Picture

Page 1 from 2

Material number: 4469.021.014

Picture: 446911600700

Material-assembly-group-no: 4469.116.007



MT-G 3080 /
INPUT

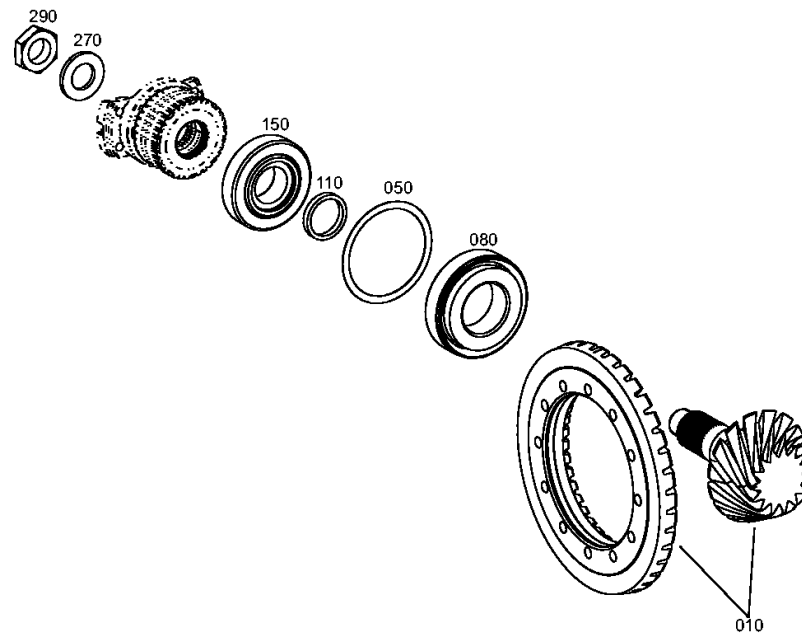

Picture

Page 2 from 2

Material number: 4469.021.014

Picture: 446911600750

Material-assembly-group-no: 4469.116.007



MT-G 3080 /
INPUT

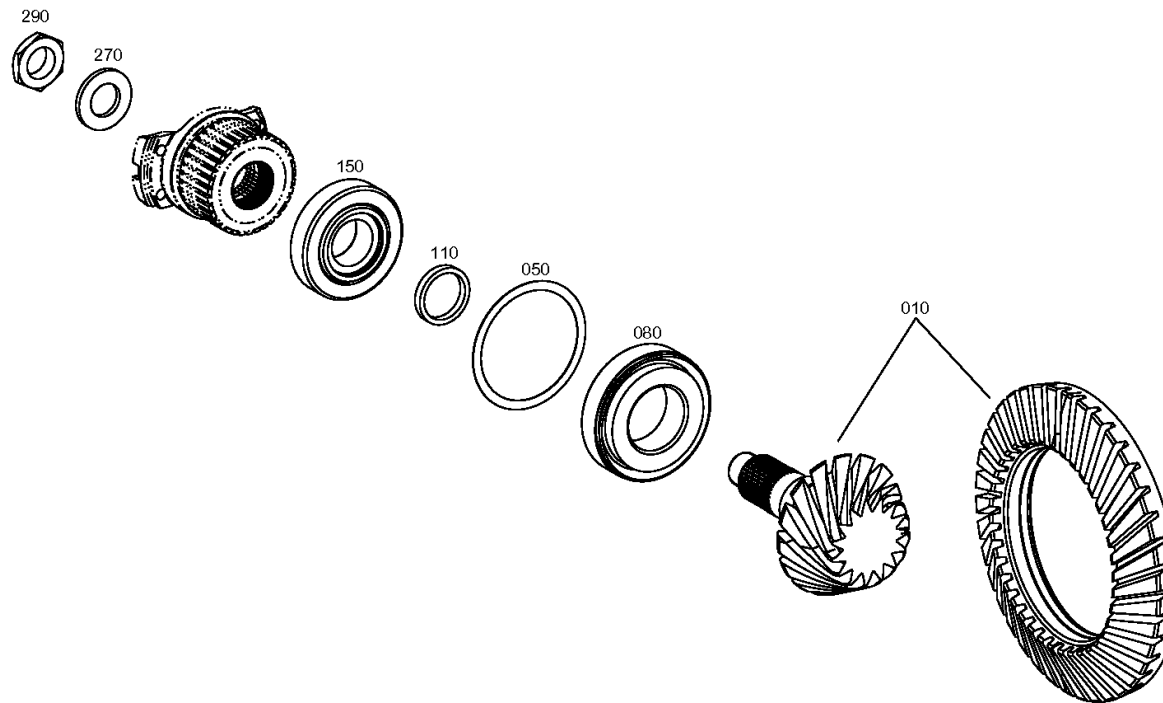

Picture

Page 1 from 1

Material number: 4469.021.014

Picture: 446911640200

Material-assembly-group-no: 4469.116.402



MT-G 3080 /
INPUT

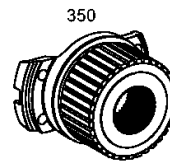

Picture

Page 1 from 1

Material number: 4469.021.014

Picture: 448117103100

Material-assembly-group-no: 4481.171.031



MT-G 3080 /
LIM.SLIP DIFF.

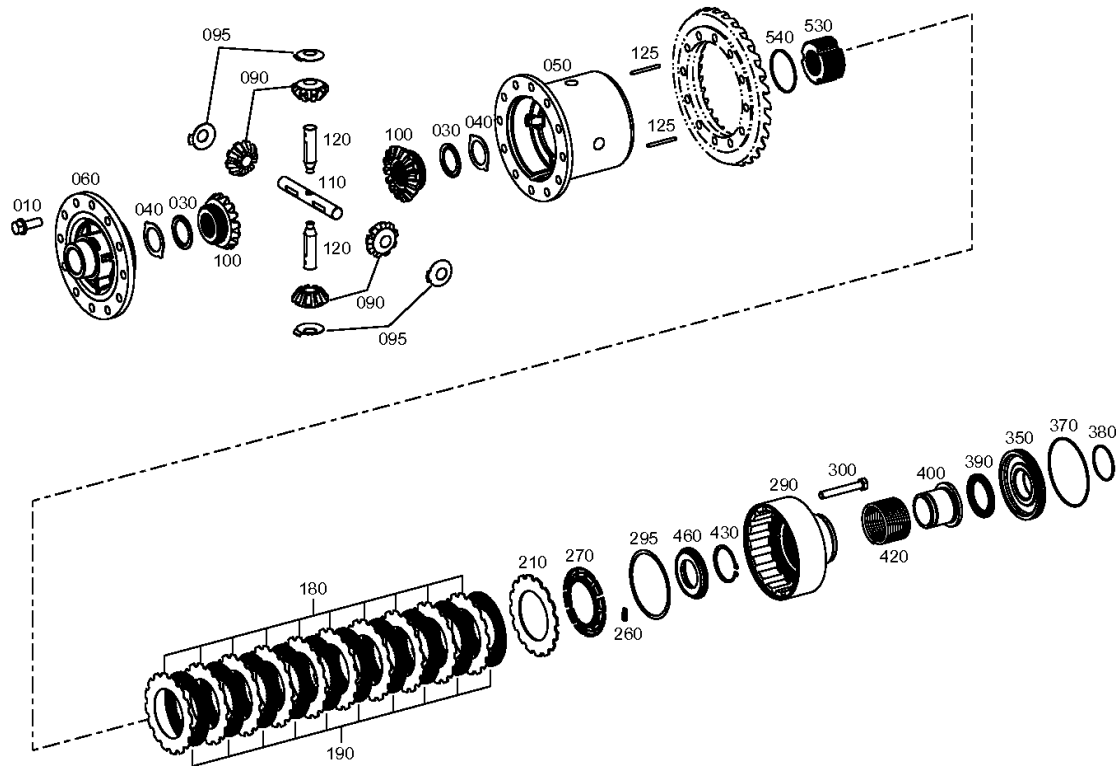

Picture

Page 1 from 1

Material number: 4469.021.014

Picture: 446911700400

Material-assembly-group-no: 4469.117.004



MT-G 3080 /
AXLE CASING

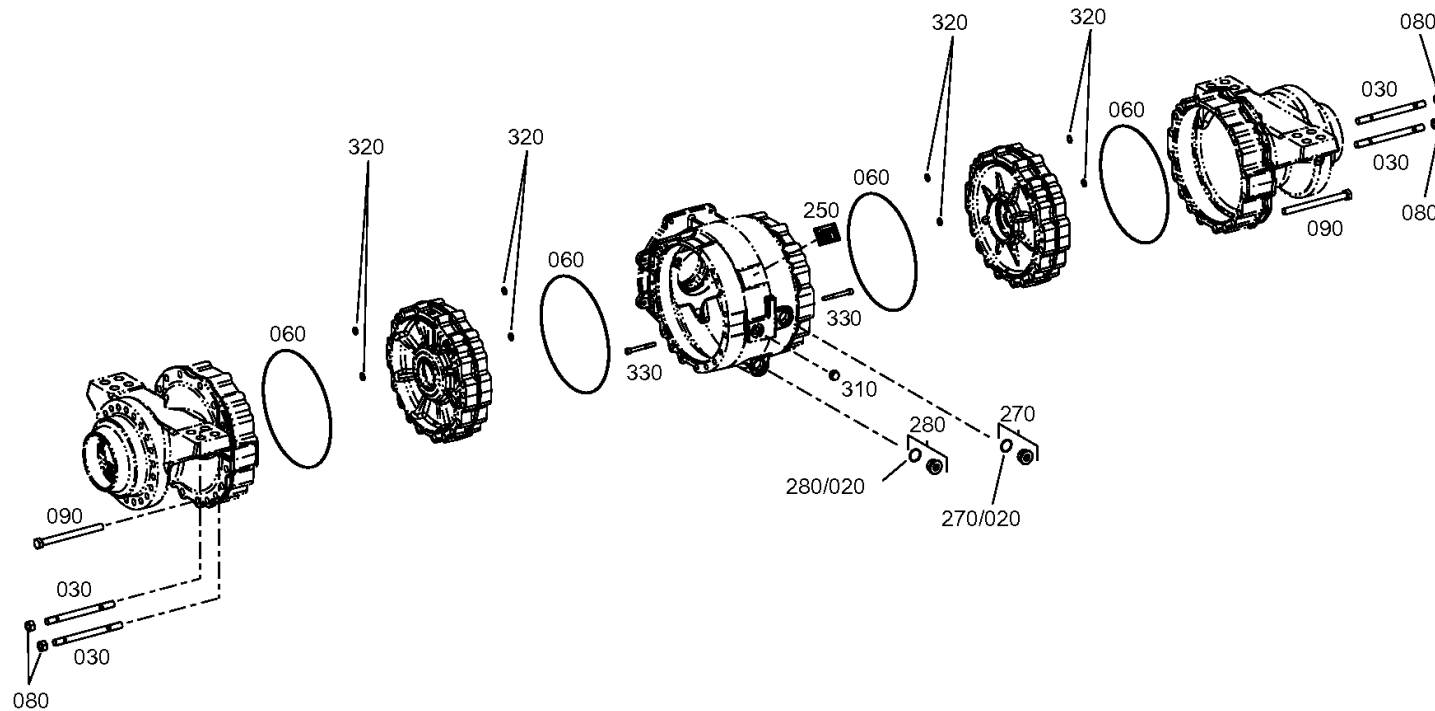

Picture

Page 1 from 1

Material number: 4469.021.014

Picture: 446911740100

Material-assembly-group-no: 4469.117.401



MT-G 3080 /
AXLE CASING

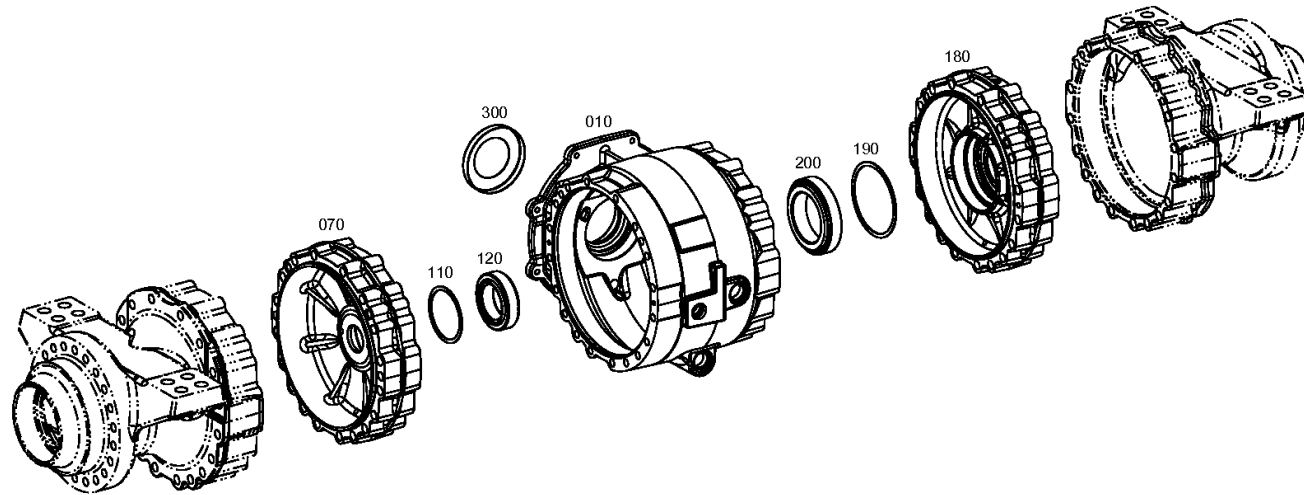

Picture

Page 1 from 1

Material number: 4469.021.014

Picture: 446911900200

Material-assembly-group-no: 4469.119.002



MT-G 3080 /
OUTPUT

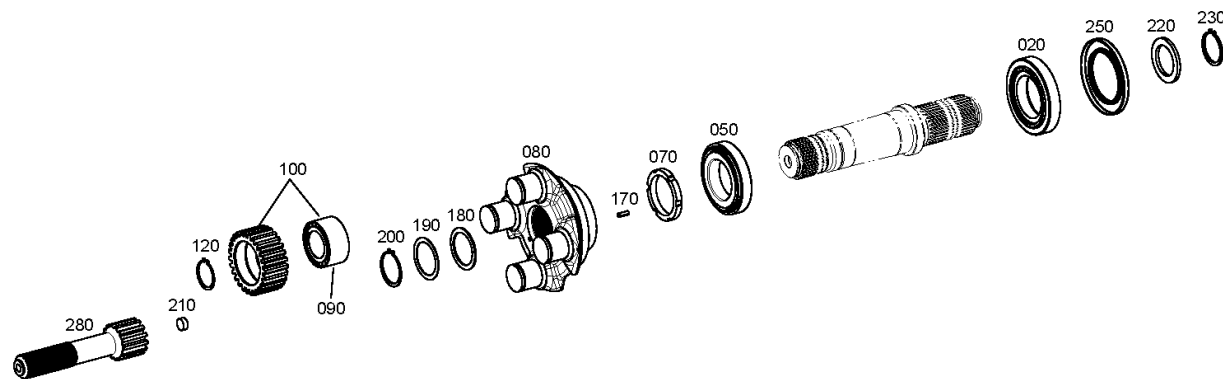

Picture

Page 1 from 1

Material number: 4469.021.014

Picture: 446911940300

Material-assembly-group-no: 4469.119.403



MT-G 3080 /
OUTPUT

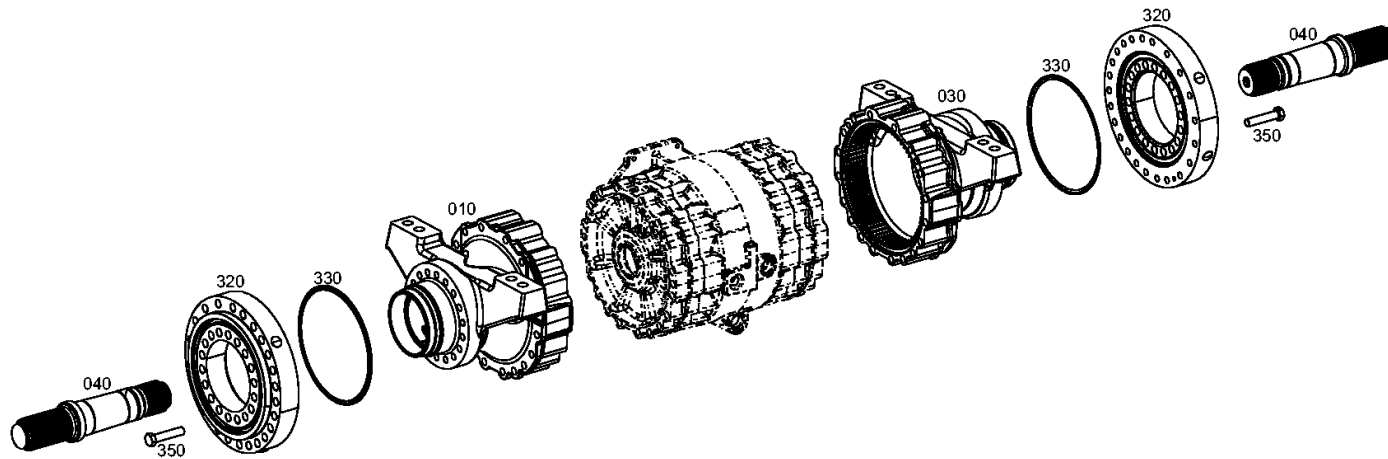

Picture

Page 1 from 1

Material number: 4469.021.014

Picture: 446912100300

Material-assembly-group-no: 4469.121.003



MT-G 3080 /
MULTIDISK BRAKE

