



Spare Parts Catalog

MT-E 3060 II

Material number: 4472.048.212

Current date: 14.02.2018

ZF Friedrichshafen AG
Hauptverwaltung
80038 Friedrichshafen
Deutschland

Telefon: +49 7541 77-0

Telefax: +49 7541 77-908000

www.zf.com

zuständiges Werk:
Passau

Notes relating to the spare parts catalog

Setup of the spare parts catalog

- Cover sheet
- Technical Cover (only in SDM print)
- Overview of figures
- Figure
- Associated parts list
- Next figure
- Associated parts list
- ...

Figure and parts list

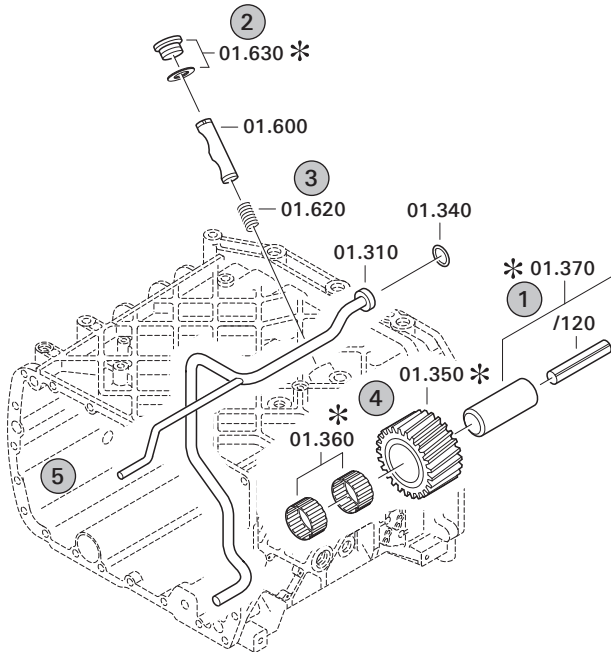

Overview of figures

Bildtafel Figure	Sachnummer Product number	Benennung (Description)	Technische Info Technical info	Description (Benennung)	Menge Quantity	Einheit Unit
068.08.17	1316.170.001	AUSLEGER	WL	SHIFT TURRET	1	Stk
068.08.06	1316.170.031	DECKEL	WL*H-H *VM	COVER	1	Stk
068.08.14	1316.170.808	DECKEL	WL*AUSL+GEH*H-H*HF160N	COVER	1	Stk
08	1316.170.441	ANSCHLUSSTEILE	WL*NG-VORB*RG-SCHL*168N *BAJONETT	CONNECTING PARTS	1	Stk

The "gap" indicates that there is no separate graphics panel (poster) for this assembly
The parts of this assembly are shown with the same mid-section number on the figure

1 Positions and subpositions

Pos.	Sachnummer Product number	Benennung (Description)	Technische Info Technical info	Description (Benennung)	Menge Quantity	Einheit Unit
0370	1315.201.054	RUECKLAUFBOLZEN	KPL.16S151*SG*L= 79	REV.IDLER SHAFT	1	Stk
/0120	0631.329.293	SPANNSTIFT		SLOT. PIN	1	Stk

Positions marked with "/" are the individual items of a completion
For example: Position 0370 contains a centering pin with the position /0120

2 Combinations with standardized parts

Pos.	Sachnummer Product number	Benennung (Description)	Technische Info Technical info	Description (Benennung)	Menge Quantity	Einheit Unit
0630		VERSCHL.SCHR.		SCREW PLUG	1	Stk
	0636.302.067	VERSCHL.SCHR.		SCREW PLUG	1	Stk
	0634.801.249	DICHTRING	A 26 X 31	SEALING RING	1	Stk

The parts list shows the components included in the combination of standardized parts

3 Depiction of position/item number on the figure and in the parts list

01.620 - on the figure 01 relates to the assembly in which the position is included. Due to program-related reasons, it is shown on the figure.

0620 - in the parts list

Pos.	Sachnummer Product number	Benennung (Description)	Technische Info Technical info	Description (Benennung)	Menge Quantity	Einheit Unit
0620	0732.040.736	DRUCKFEDER		COMPRESSION SPRING	1	Stk

4 *-Positions

Positions marked with an * are optional i.e. inclusion in the parts list is not mandatory.
The following note is shown on the figure

je nach Stücklistenausführung
depending on spec. number
*
suivant la nomenclature
secondo la distinta base

5 Parts, dotted display

Parts with dotted display on the figure are only used for orientation of other parts

Technical Cover

Page 1 from 2

Material number: 4472.048.212



MT-E 3060 II /

Pos.	Information	Amendment number
	CUSTOMER: HYUNDAI	
	CUSTOMER-IDENT-NO.:	
	VEHICLE DESIGNATION: R170W-7A	
	TYRE SIZE: 10.00-20	
	TYRE RADIUS DYN.: 0,515 M	
	MAX. SPEED: 30 KM/H	
	TRACK WIDTH: 1.944 MM	
	PRODUCT DESCRIPTION: ZF- MULTITRAC-AXLE	
	VEHICLE TYPE: MOBILE EXCAVATOR	
	AXLE TYPE: MT-E 3060 II	
	VERSION: RIGID	
	AXLE ARRANGEMENT: REAR AXLE	
	DIRECTION OF ROTATION: CCW	
	CROWN WHEEL POSITION: LEFT	
	SPIRAL DIRECTION: LEFT	
	T/M MOUNTING: WITHOUT	
	INPUT FLANGE: DIN 120	
	FLANGE TO FLANGE DIM.: 1.920 MM	
	AXLE INSTALLATION: SPRING PAD	
	MAIN DIFFERENTIAL: OPEN	
	AXLE RATIO: 22,110	
	PLANETARY DRIVE: P3, I=6,4	
	SERVICE BRAKE : MULTI-DISC BRAKE 235X155X5,5	
	BRAKE PORT SIZE: M14 X 1,5	
	RIM PITCH CIRCLE DIAM.: 335,00 MM	
	WHEEL CONNECTION: BOLT 10 X M22 X 1,5 X 87	
	WHEEL NUTS: WITH	
	OIL FILLING AXLE DRIVE: WITH	
	OIL - GRADE AXLE DRIVE: TE ML 05 (TITAN POWERFLUID)	
	OIL - GRADE ALLOWED: TE ML 05 C/D/E/F/G	
	PRIMER PAINT: BLACK RAL 9005	
	TYPE PLATE: ZF- STANDARD	
	PLANETARY DRIVE OIL CAP 2,50 L	

Technical Cover

Page 2 from 2

Material number: 4472.048.212



MT-E 3060 II /

Pos.	Information	Amendment number
	AXLE HOUSING OIL CAPACI 12,40 L	
	OIL FILL QUANTITY CA: 17,40 L	
	DOCUMENTATION: -----	
	SECTION DRAWING: 4472.048.216	
	INSTALLATION DRAWING: 4472.648.013	
	INSTALLATION INSTRUCTIO 4472.700.067	
	TESTING INSTRUCTION: 4472 760 021	
	PAINT-FREE AREA: 4472.700.068	

Assembly group overview

Page 1 from 1



MT-E 3060 II /

Material number: 4472.048.212

Graphics	Pos.	Material number	Name	Quantity	Amend. no.	Techn. Info.
447212502450	10	4472.125.024	INPUT	1		
447212540550	20	4472.125.405	INPUT	1		
448203000100	30	4482.030.001	DIFFERENTIAL	1		
447212601150	70	4472.126.011	AXLE CASING	1		
447212643400	80	4472.126.434	AXLE CASING	1		
447212900900	120	4472.129.009	HUB CARRIER	1		
447213303700	130	4472.133.037	OUTPUT	1		
447213340700	140	4472.133.407	OUTPUT	1		
414313900100	900	4143.139.001	TYPE PLATE	1		

Plant

Page 1 from 1

Material number: 4472.048.212

Plant: 447212502450

Material-assembly-group-no: 4472.125.024



MT-E 3060 II /
INPUT

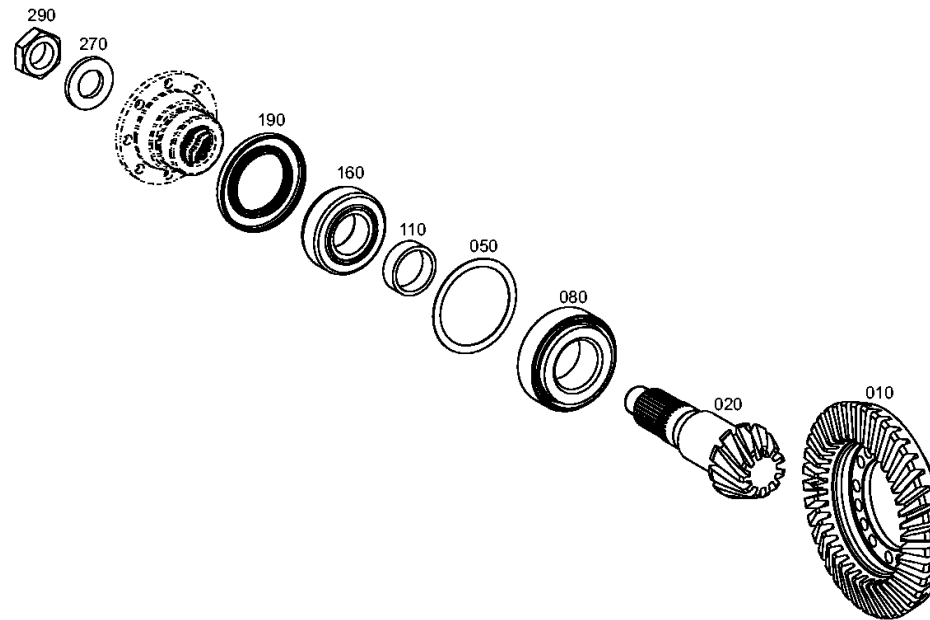

Plant

Page 1 from 1

Material number: 4472.048.212

Plant: 447212540550

Material-assembly-group-no: 4472.125.405



MT-E 3060 II /
INPUT

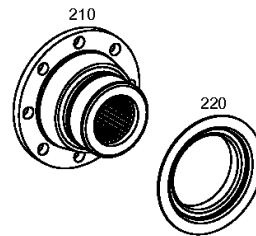

Plant

Page 1 from 2

Material number: 4472.048.212

Plant: 448203000100

Material-assembly-group-no: 4482.030.001



MT-E 3060 II /
DIFFERENTIAL

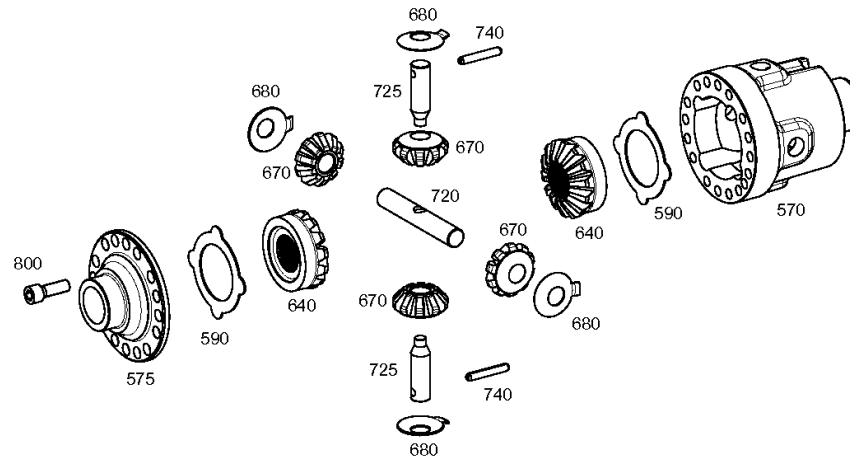

Plant

Page 2 from 2

Material number: 4472.048.212

Plant: 448203000150

Material-assembly-group-no: 4482.030.001



MT-E 3060 II /
DIFFERENTIAL

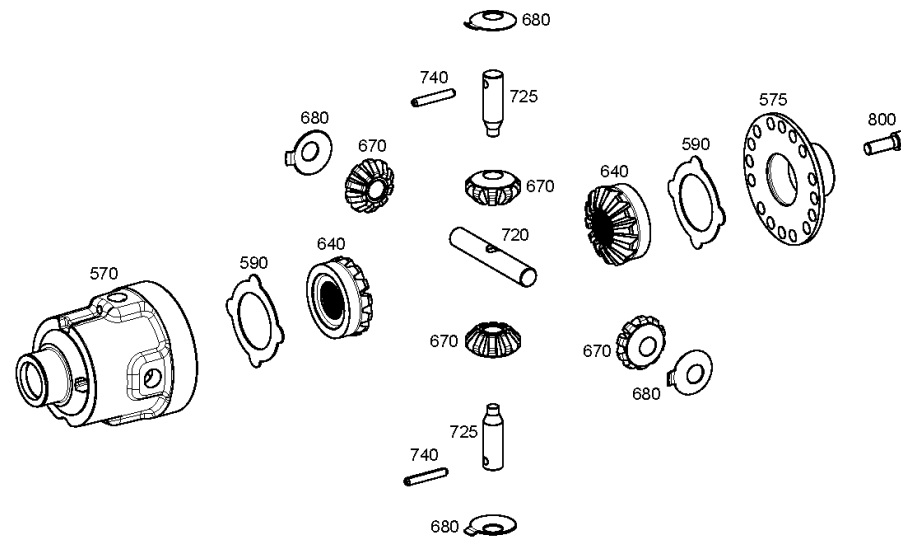

Plant

Page 1 from 1

Material number: 4472.048.212

Plant: 447212601150

Material-assembly-group-no: 4472.126.011



MT-E 3060 II /
AXLE CASING

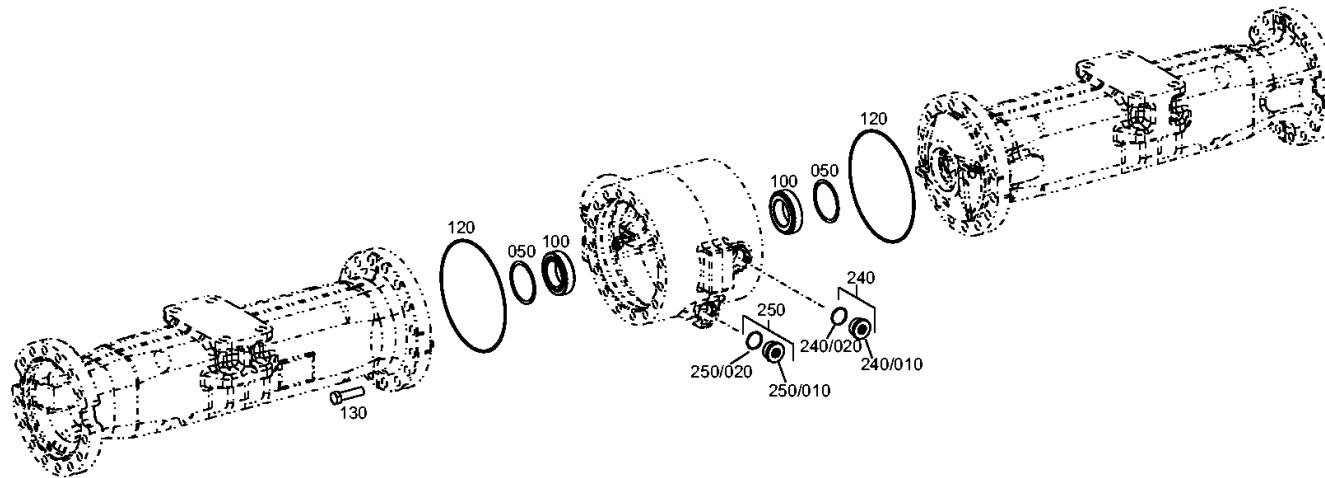

Plant

Page 1 from 1

Material number: 4472.048.212

Plant: 447212643400

Material-assembly-group-no: 4472.126.434



MT-E 3060 II /
AXLE CASING

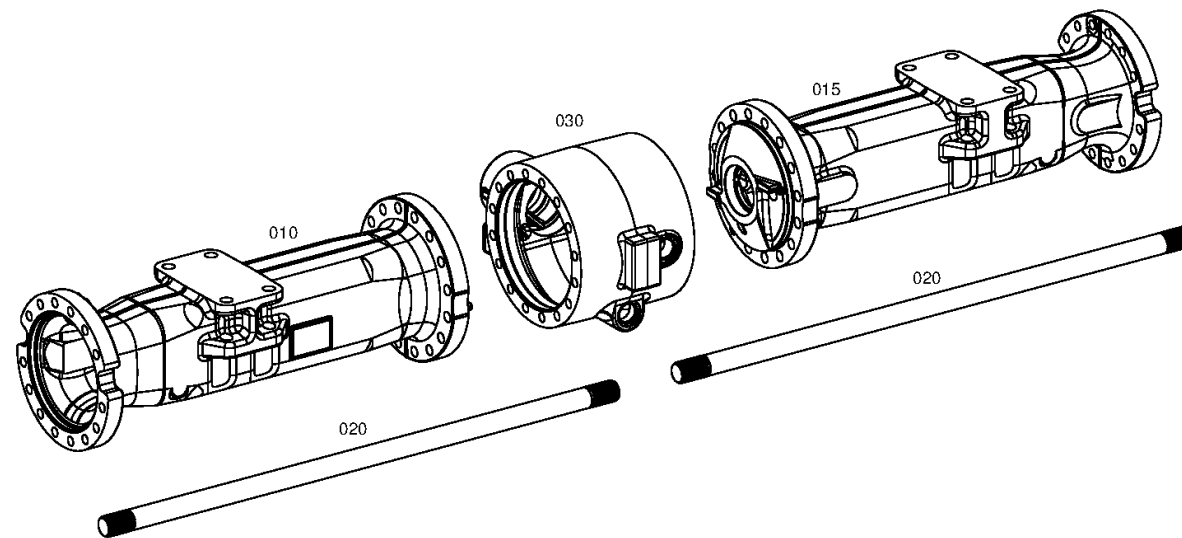

Plant

Page 1 from 1

Material number: 4472.048.212

Plant: 447212900900

Material-assembly-group-no: 4472.129.009



MT-E 3060 II /
HUB CARRIER

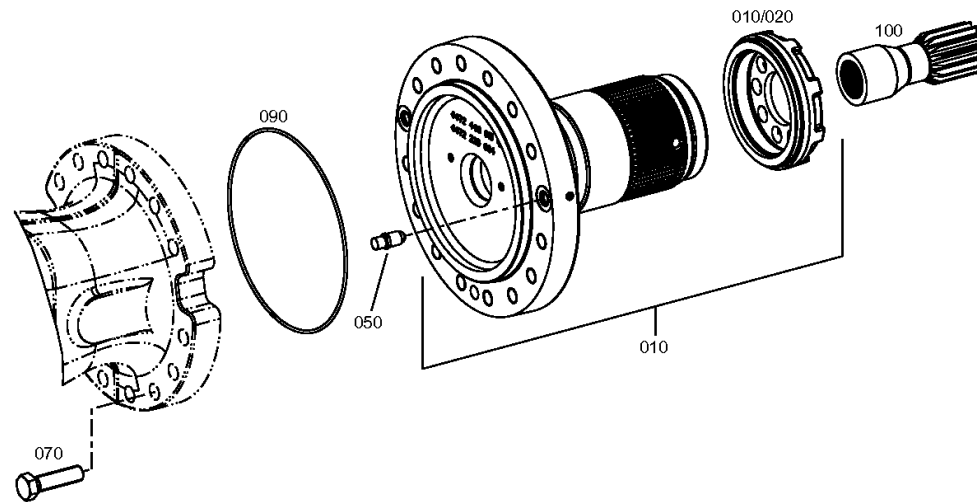

Plant

Page 1 from 1

Material number: 4472.048.212

Plant: 447213303700

Material-assembly-group-no: 4472.133.037



MT-E 3060 II /
OUTPUT

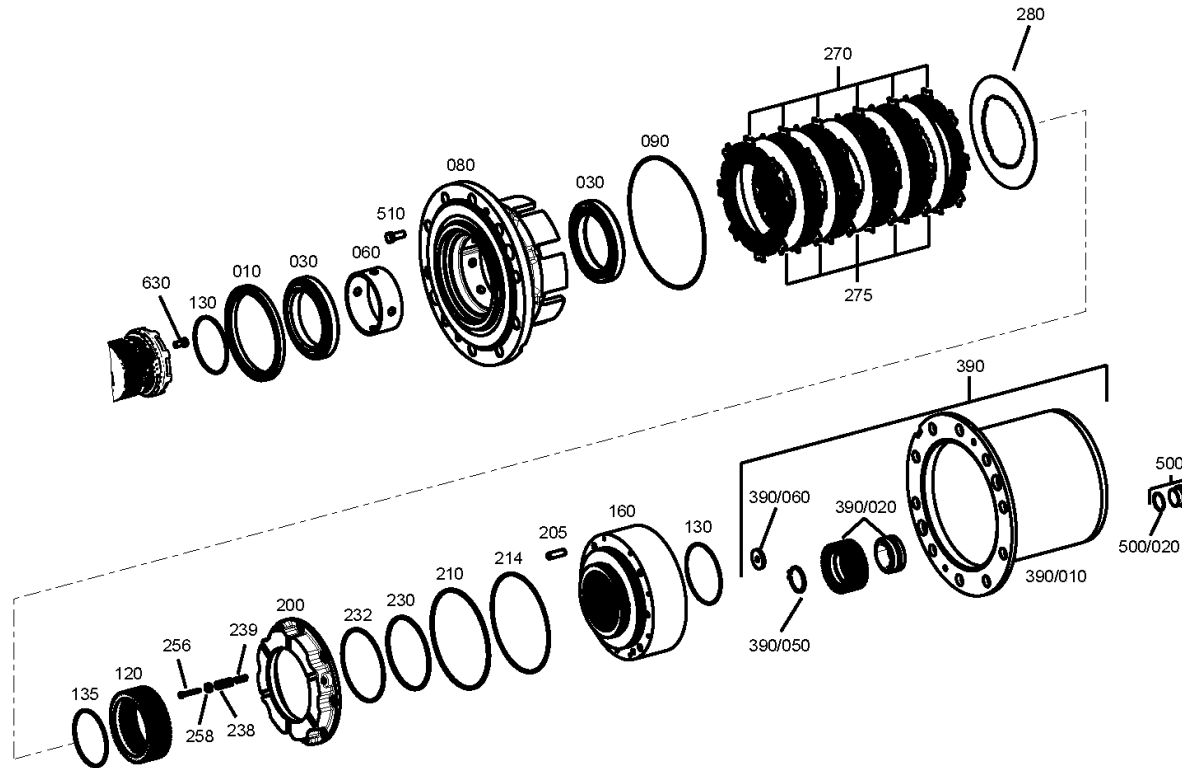

Plant

Page 1 from 1

Material number: 4472.048.212

Plant: 447213340700

Material-assembly-group-no: 4472.133.407



MT-E 3060 II /
OUTPUT

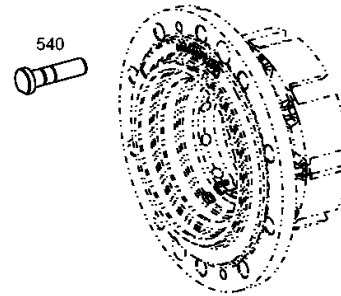

Plant

Page 1 from 1

Material number: 4472.048.212

Plant: 414313900100

Material-assembly-group-no: 4143.139.001



MT-E 3060 II /
TYPE PLATE



010