



Spare Parts Catalog

MT-E 3070 II

Material number: 4472.049.202

Current date: 10.03.2023

ZF Friedrichshafen AG
Hauptverwaltung
80038 Friedrichshafen
Deutschland

Telefon: +49 7541 77-0

Telefax: +49 7541 77-908000

www.zf.com

zuständiges Werk:
Passau

Notes relating to the spare parts catalog

Setup of the spare parts catalog

- Cover sheet
- Technical Cover (only in SDM print)
- Overview of figures
- Figure
- Associated parts list
- Next figure
- Associated parts list
- ...

Figure and parts list



Overview of figures

Bildtafel Figure	Sachnummer Product number	Benennung (Description)	Technische Info Technical info	Description (Benennung)	Menge Quantity	Einheit Unit
068.08.17	1316.170.001	AUSLEGER	WL	SHIFT TURRET	1	Stk
068.08.06	1316.170.031	DECKEL	WL*H-H *VM	COVER	1	Stk
068.08.14	1316.170.808	DECKEL	WL*AUSL+GEH*H-H*HF160N	COVER	1	Stk
08	1316.170.441	ANSCHLUSSTEILE	WL*NG-VORB*RG-SCHL*168N *BAJONETT	CONNECTING PARTS	1	Stk

The "gap" indicates that there is no separate graphics panel (poster) for this assembly
The parts of this assembly are shown with the same mid-section number on the figure

1 Positions and subpositions

Pos.	Sachnummer Product number	Benennung (Description)	Technische Info Technical info	Description (Benennung)	Menge Quantity	Einheit Unit
0370	1315.201.054	RUECKLAUFBOLZEN	KPL.16S151*SG*L= 79	REV.IDLER SHAFT	1	Stk
/0120	0631.329.293	SPANNSTIFT		SLOT. PIN	1	Stk

Positions marked with "/" are the individual items of a completion
For example: Position 0370 contains a centering pin with the position /0120

2 Combinations with standardized parts

Pos.	Sachnummer Product number	Benennung (Description)	Technische Info Technical info	Description (Benennung)	Menge Quantity	Einheit Unit
0630		VERSCHL.SCHR.		SCREW PLUG	1	Stk
	0636.302.067	VERSCHL.SCHR.		SCREW PLUG	1	Stk
	0634.801.249	DICHTRING	A 26 X 31	SEALING RING	1	Stk

The parts list shows the components included in the combination of standardized parts

3 Depiction of position/item number on the figure and in the parts list

01.620 - on the figure 01 relates to the assembly in which the position is included. Due to program-related reasons, it is shown on the figure.

0620 - in the parts list

Pos.	Sachnummer Product number	Benennung (Description)	Technische Info Technical info	Description (Benennung)	Menge Quantity	Einheit Unit
0620	0732.040.736	DRUCKFEDER		COMPRESSION SPRING	1	Stk

4 *-Positions

Positions marked with an * are optional i.e. inclusion in the parts list is not mandatory.
The following note is shown on the figure

je nach Stücklistenausführung
depending on spec. number
*
suivant la nomenclature
secondo la distinta base

5 Parts, dotted display

Parts with dotted display on the figure are only used for orientation of other parts

Technical Cover

Page 1 from 2

Material number: 4472.049.202



MT-E 3070 II /

Pos.	Information	Amendment number
	KUNDENNAME: LIEBHERR-KIRCHDORF	
	KUNDEN-IDENT-NUMMER: 10476869	
	FAHRZEUGBEZEICHNUNG: A904C; A914C	
	REIFENGROESSE: 10.00-20	
	REIFENRADIUS DYN: 0,505 M	
	ENDGESCHWINDIGKEIT: 20 KM/H	
	SPURWEITE: 1.914 MM	
	PRODUKTBESCHREIBUNG: ZF- MULTITRAC ACHSE	
	FAHRZEUGART: MOBILBAGGER	
	ACHSENTYP: MT-E 3070	
	AUSFUEHRUNG: STARR	
	ACHSANORDNUNG: HINTERACHSE	
	DREHRICHTUNG RITZEL: EDUL	
	TELLERRADLAGE: LINKS	
	SPIRALRICHTUNG: LINKS	
	GETRIEBEANBAU: OHNE	
	ANTRIEBSFLANSCH: DIN 120	
	FLANSCHMASS.: 1.890 MM	
	AUFHAENGUNG: FEDERBLATT	
	QUERDIFFERENTIAL: OFFEN	
	ACHSUEBERSETZUNG: 16,000	
	PLANETENTRIEB: P3, I=6,4	
	BETRIEBSBREMSE: LAMELLENBREMSE 235 X 155 X 6,5	
	BREMSANSCHLUSS: M14 X 1,5	
	FELGENLOCHKREIS: 335,00 MM	
	RADANSCHLUSS: BOLZEN 10 X M22 X 1,5 X 87	
	RADMUTTER: OHNE	
	ACHSE OELFUELLUNG: MIT	
	OELSORTE: TE ML 05 (TITAN POWERFLUID)	
	OELSORTE ZUL.: TE ML 05 C/D/E/F/G	
	FARBE: VERKEHRSGRAU RAL 7043	
	ABD. FARBFREIE FLAECHE: STANDARD MOBILBAGGER	
	TYPENSCHILD: LIEBHERR	



Pos.	Information	Amendment number
	OELMENGE PLANETENTRIEB: 2,50 L	
	OELMENGE ACHSBRUECKE: 13,00 L	
	OELMENGE GESAMT CA: 18,00 L	
	DOKUMENTATION: -----	
	SCHNITTZEICHNUNG: 4472.049.218	
	EINBAUZEICHNUNG: 4472.649.014	
	EINBAURICHTLINIEN: 4472.700.067	
	PRÜFANWEISUNG: 4472.760.021	
	FARBREIE FLAECHE: 4472.700.068	

Assembly group overview

Page 1 from 1

Material number: 4472.049.202



MT-E 3070 II /

Picture	Pos.	Material number	Name	Quantity	Amend. no.	Techn. Info.
447212502550	10	4472.125.025	INPUT	1		
447212540550	20	4472.125.405	INPUT	1		
448204000250	30	4482.040.002	DIFFERENTIAL 750	1		
447212601250	70	4472.126.012	AXLE CASING	1		
447212644300	80	4472.126.443	AXLE CASING	1		
447212901000	120	4472.129.010	HUB CARRIER	1		
447213303800	130	4472.133.038	OUTPUT	1		
447213340700	140	4472.133.407	OUTPUT	1		
414313900300	900	4143.139.003	TYPE PLATE	1		
447229818800	KIT	4472.298.188	OUTPUT	1		

Picture

Page 1 from 1

Material number: 4472.049.202

Picture: 447212502550

Material-assembly-group-no: 4472.125.025



MT-E 3070 II /
INPUT

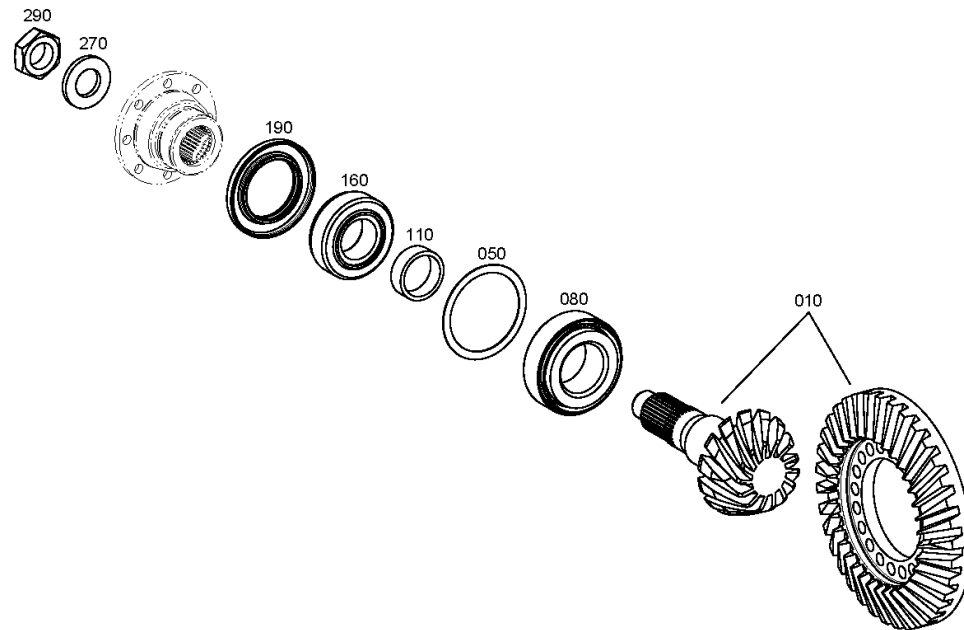

Picture

Page 1 from 1

Material number: 4472.049.202

Picture: 447212540550

Material-assembly-group-no: 4472.125.405



MT-E 3070 II /
INPUT

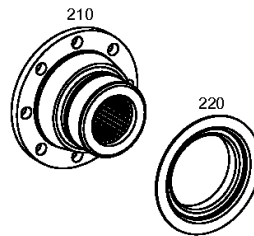

Picture

Page 1 from 1

Material number: 4472.049.202

Picture: 448204000250

Material-assembly-group-no: 4482.040.002



MT-E 3070 II /
DIFFERENTIAL 750

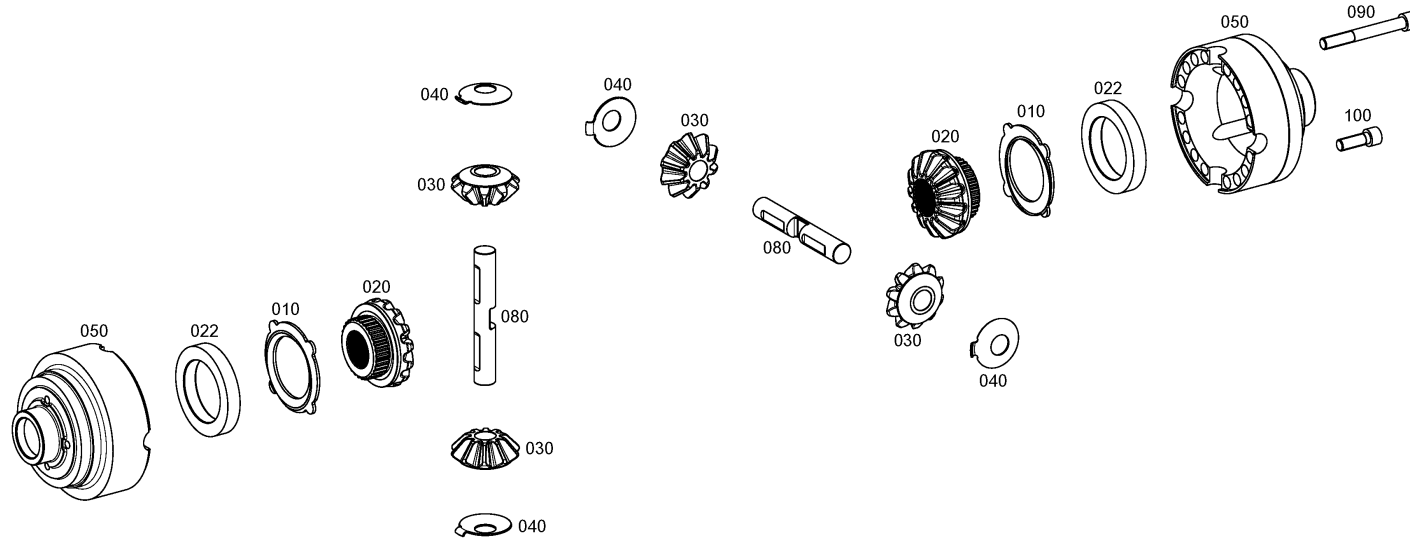

Picture

Page 1 from 1

Material number: 4472.049.202

Picture: 447212601250

Material-assembly-group-no: 4472.126.012



MT-E 3070 II /
AXLE CASING

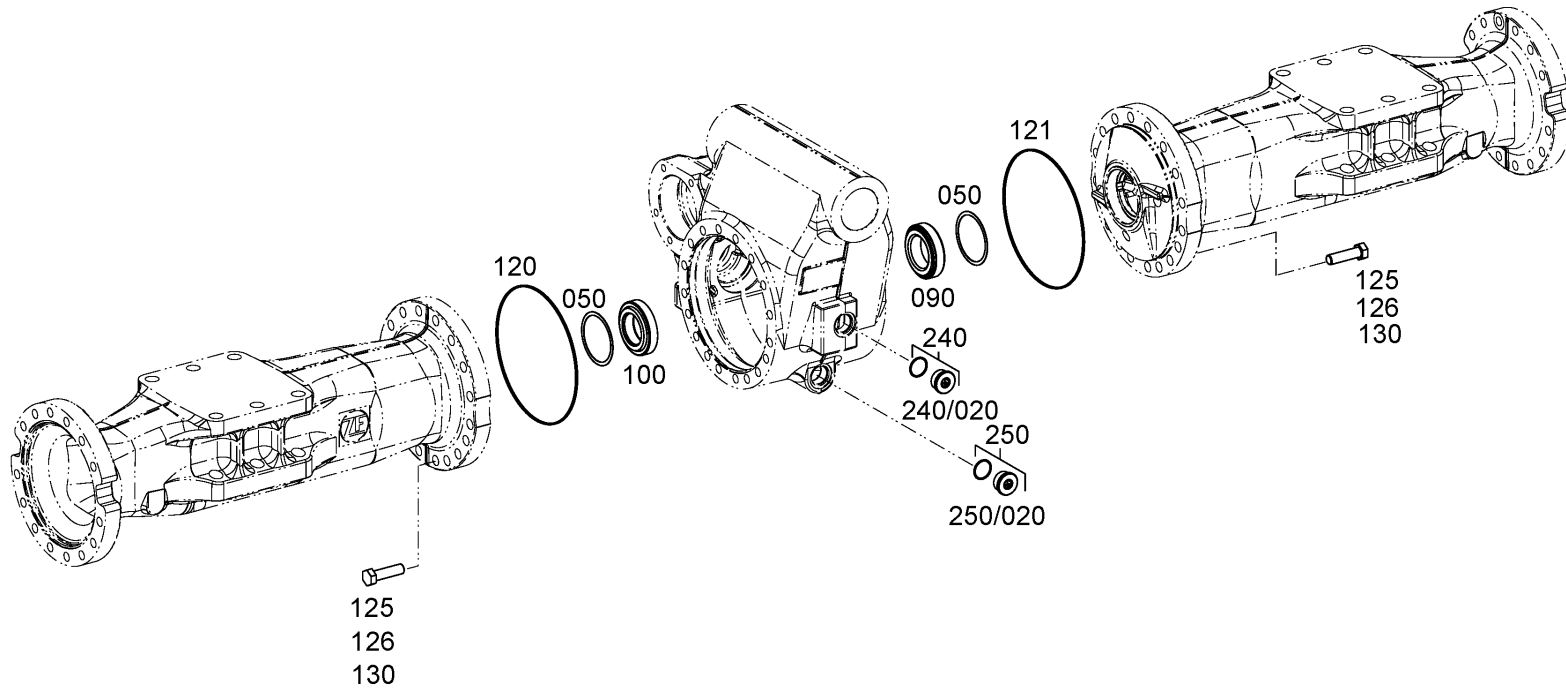

Picture

Page 1 from 1

Material number: 4472.049.202

Picture: 447212644300

Material-assembly-group-no: 4472.126.443



MT-E 3070 II /
AXLE CASING

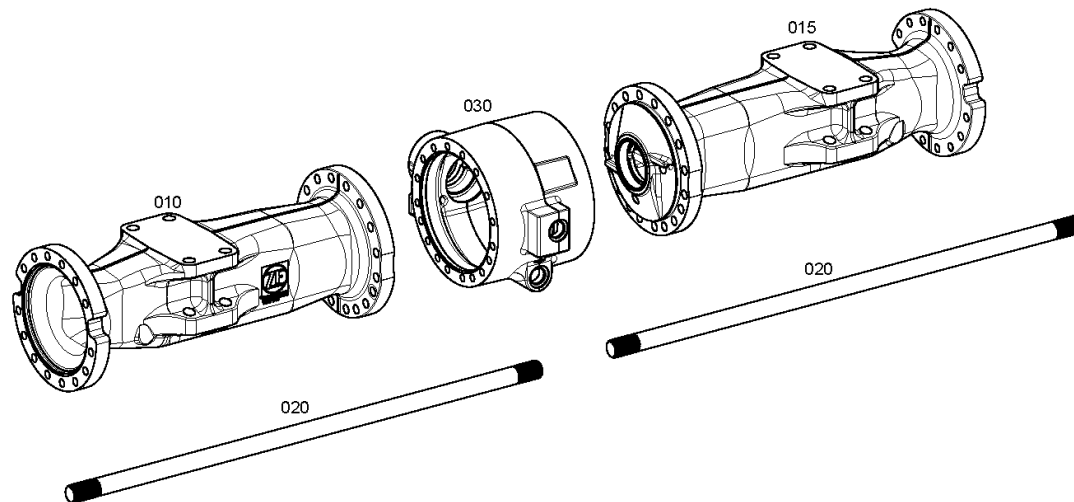

Picture

Page 1 from 1

Material number: 4472.049.202

Picture: 447212901000

Material-assembly-group-no: 4472.129.010



MT-E 3070 II /
HUB CARRIER

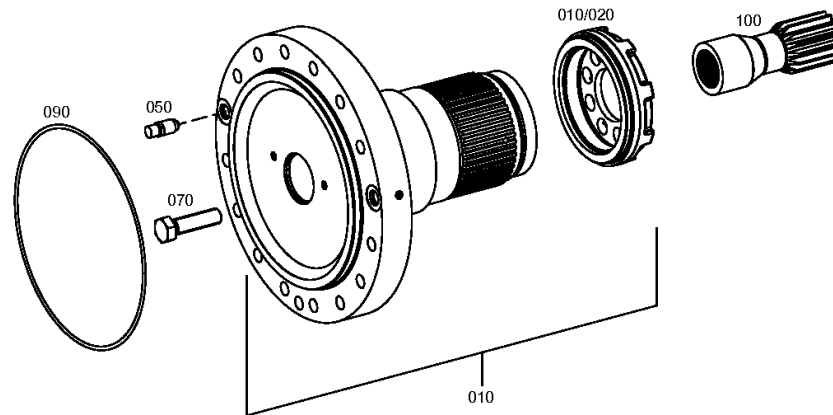

Picture

Page 1 from 1

Material number: 4472.049.202

Picture: 447213303800

Material-assembly-group-no: 4472.133.038



MT-E 3070 II /
OUTPUT

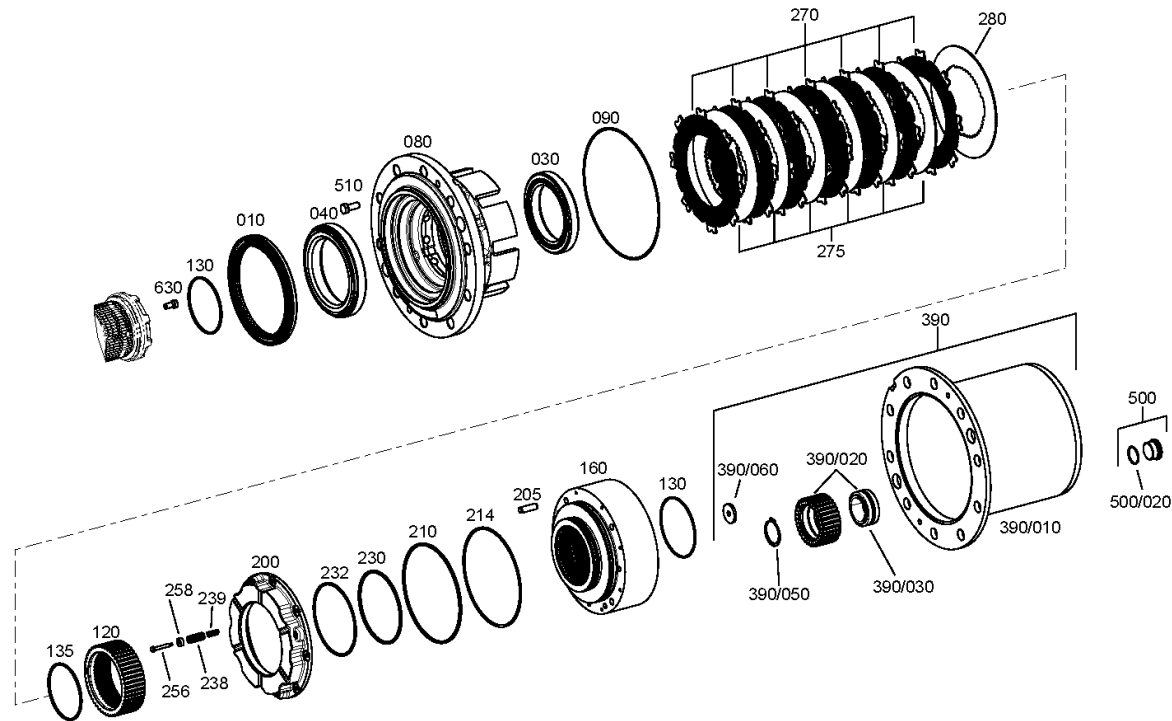

Picture

Page 1 from 1

Material number: 4472.049.202

Picture: 447213340700

Material-assembly-group-no: 4472.133.407



MT-E 3070 II /
OUTPUT

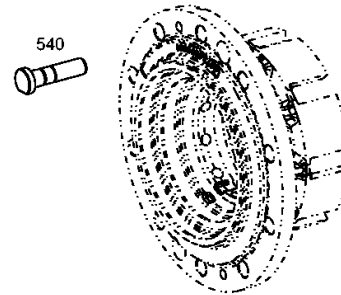

Picture

Page 1 from 1

Material number: 4472.049.202

Picture: 414313900300

Material-assembly-group-no: 4143.139.003



MT-E 3070 II /
TYPE PLATE

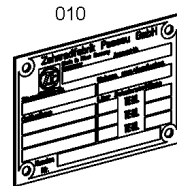

Picture

Page 1 from 1

Material number: 4472.049.202

Picture: 447229818800

Material-assembly-group-no: 4472.298.188



MT-E 3070 II /
OUTPUT

