



Spare Parts Catalog

MS-E 3060

Material number: 4472.098.014

Current date: 29.03.2018

ZF Friedrichshafen AG
Hauptverwaltung
80038 Friedrichshafen
Deutschland

Telefon: +49 7541 77-0

Telefax: +49 7541 77-908000

www.zf.com

zuständiges Werk:
Passau

Notes relating to the spare parts catalog

Setup of the spare parts catalog

- Cover sheet
- Technical Cover (only in SDM print)
- Overview of figures
- Figure
- Associated parts list
- Next figure
- Associated parts list
- ...

Figure and parts list

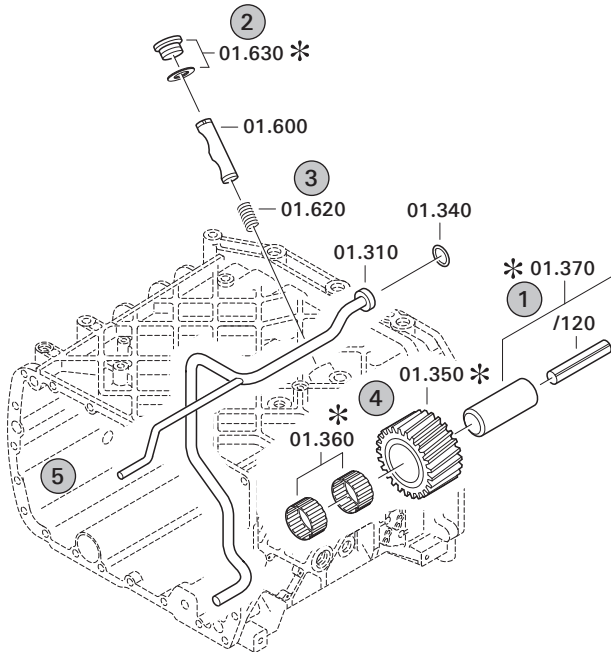

Overview of figures

Bildtafel Figure	Sachnummer Product number	Benennung (Description)	Technische Info Technical info	Description (Benennung)	Menge Quantity	Einheit Unit
068.08.17	1316.170.001	AUSLEGER	WL	SHIFT TURRET	1	Stk
068.08.06	1316.170.031	DECKEL	WL*H-H *VM	COVER	1	Stk
068.08.14	1316.170.808	DECKEL	WL*AUSL+GEH*H-H*HF160N	COVER	1	Stk
08	1316.170.441	ANSCHLUSSTEILE	WL*NG-VORB*RG-SCHL*168N *BAJONETT	CONNECTING PARTS	1	Stk

The "gap" indicates that there is no separate graphics panel (poster) for this assembly
The parts of this assembly are shown with the same mid-section number on the figure

1 Positions and subpositions

Pos.	Sachnummer Product number	Benennung (Description)	Technische Info Technical info	Description (Benennung)	Menge Quantity	Einheit Unit
0370	1315.201.054	RUECKLAUFBOLZEN	KPL.16S151*SG*L= 79	REV.IDLER SHAFT	1	Stk
/0120	0631.329.293	SPANNSTIFT		SLOT. PIN	1	Stk

Positions marked with "/" are the individual items of a completion
For example: Position 0370 contains a centering pin with the position /0120

2 Combinations with standardized parts

Pos.	Sachnummer Product number	Benennung (Description)	Technische Info Technical info	Description (Benennung)	Menge Quantity	Einheit Unit
0630		VERSCHL.SCHR.		SCREW PLUG	1	Stk
	0636.302.067	VERSCHL.SCHR.		SCREW PLUG	1	Stk
	0634.801.249	DICHTRING	A 26 X 31	SEALING RING	1	Stk

The parts list shows the components included in the combination of standardized parts

3 Depiction of position/item number on the figure and in the parts list

01.620 - on the figure 01 relates to the assembly in which the position is included. Due to program-related reasons, it is shown on the figure.

0620 - in the parts list

Pos.	Sachnummer Product number	Benennung (Description)	Technische Info Technical info	Description (Benennung)	Menge Quantity	Einheit Unit
0620	0732.040.736	DRUCKFEDER		COMPRESSION SPRING	1	Stk

4 *-Positions

Positions marked with an * are optional i.e. inclusion in the parts list is not mandatory.
The following note is shown on the figure

je nach Stücklistenausführung
depending on spec. number
*
suivant la nomenclature
secondo la distinta base

5 Parts, dotted display

Parts with dotted display on the figure are only used for orientation of other parts

Technical Cover

Page 1 from 2

Material number: 4472.098.014



MS-E 3060 /

Pos.	Information	Amendment number
	CUSTOMER:SENNEBOGEN GMBH,MASCH.	
	IDENT-NO.: WITHOUT	
	APPROVAL:	
	QUESTIONNAIRE:	
	WITHOUT	
	PROJECT-NO.:	
	VEHICLE DATA:	
	821M-C / 613	
	MOTOR: HYDROMOTOR A6VM 107	
	GETRIEBE: 2 HL-270	
	DUAL TIRES: DOUBLE	
	TIRE: 10.0-20	
	R.DYN. 0,498 M	
	RIM PITCH CIRCLE DIA: 335 MM	
	MAX.SPEED: 20,0 KM/H	
	PRODUCT DESCRIPTION:	
	MOUNTING POSITION:FRONT AXLE	
	UEBERSETZUNG GES:I= 18,67	
	PLANETENTRIEB: I= 6,40 P3-245-45	
	KEGELTRIEB: I= 2,92 Z=35/12	
	BEFESTIGUNG: FEDERSPUR L=805/1035/1265	
	FLANSCHMASS: L=1920	
	BRAKE:	
	LAM.BR.: HYDR: 155X235	
	LINIG DISC: 6 LUMP	
	ARBEITSZYLINDER: INTEGRIERT/ D=90X50/200 BAR	
	DIFF.CARRIER:	
	TYP/GROESSE: AE 500 KV	
	SENS OF ROTATION:CLOCKWISE	
	RING GEAR: SPIRAL DIRECTION LEFT	
	POSITION OF RING GEAR: LEFT	
	FLANGE CONN: AD=120 *LZ=8 * D=10,1	
	DIFFERENTIAL:	

Technical Cover

Page 2 from 2

Material number: 4472.098.014



MS-E 3060 /

Pos.	Information	Amendment number
	TYP/GROESSE: D 500	
	BEVEL SIDE GEAR SPLINE: N 35X1,25	
	DRAWINGS:	
	SCHNITT: 4472 098 002()	
	EINBAU: 4472 698 001(0)	
	PRUEFANWEISUNG: 4472 760 021	
	ASSEMBLY INSTRUCTION:	
	LENKEINSCHLAG: 29 GRAD - 1 GRAD	
	VORSPUR: +/- 1MM BEI 330MM MESSSCHENKELLAENGE	
	RADBOLZEN MIT SCHUTZHUELSE VOR FARBE SCHUETZEN	
	KOLBENHUB 0,7 - 1,3 MM	
	AUXILIARY UNIT	
	OIL CAPACITY:	
	AXLE: CA. 9,50L	
	PLANETENTRIEB/JE:CA. 2,50L	
	GESAMT: CA. 14,50L	
	OIL FILLING: YES	
	OIL GRADE:SPECIFICATION TE ML 05 / AXLE	
	BRAKE CONTROL: ATF-OIL/MOTOROIL 10 W	
	WEIGHT-TOTAL: ...KG	
	COLOUR: UMBRAGREY RAL 7022	
	MISCELLANEOUS/REMARKS:	
	SWINGING AXLE SUSPENSION	
	TYPE/ SERIAL NUMBER/ PART LIST NUMBER AND	
	OIL SPECIFICATION IN NAME PLATE	

Assembly group overview

Page 1 from 1

Material number: 4472.098.014



MS-E 3060 /

Graphics	Pos.	Material number	Name	Quantity	Amend. no.	Techn. Info.
447212500800	10	4472.125.008	INPUT	1		
447212540000	20	4472.125.400	INPUT	1		
446117304750	30	4461.173.047	DIFFERENTIAL	1		
447212600200	70	4472.126.002	AXLE CASING	1		
447212640900	80	4472.126.409	AXLE CASING	1		
447212800600	90	4472.128.006	JOINT HOUSING	1		
447212840100	100	4472.128.401	JOINT HOUSING	1		
447213400200	150	4472.134.002	STEERING	1		
447213301100	130	4472.133.011	OUTPUT	1		
447213340100	140	4472.133.401	OUTPUT	1		
414313900100	900	4143.139.001	TYPE PLATE	1		
447229816000	KIT	4472.298.160	JOINT HOUSING	1		
447229816100	KIT	4472.298.161	JOINT HOUSING	1		
	KIT	4472.298.208	JOINT HOUSING	1		
	KIT	4472.298.209	JOINT HOUSING	1		
	KIT	4472.298.228	JOINT HOUSING	1		
	KIT	4472.298.229	JOINT HOUSING	1		

Plant

Page 1 from 1

Material number: 4472.098.014

Plant: 447212500800

Material-assembly-group-no: 4472.125.008



MS-E 3060 /
INPUT

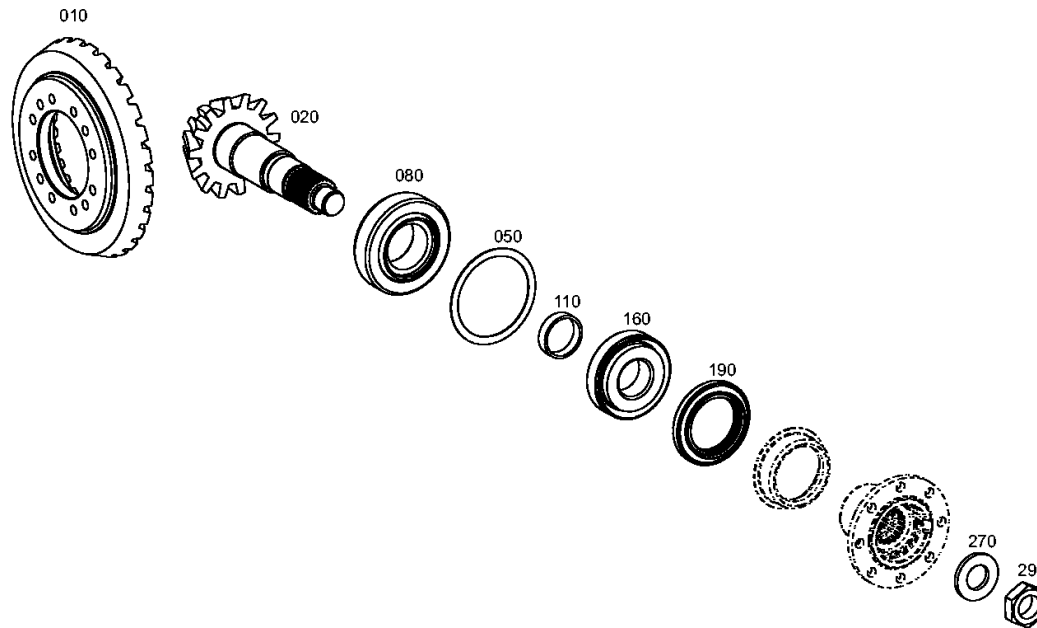

Plant

Page 1 from 1

Material number: 4472.098.014

Plant: 447212540000

Material-assembly-group-no: 4472.125.400



MS-E 3060 /
INPUT

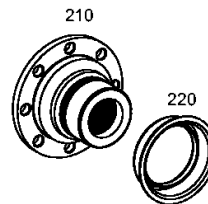

Plant

Page 1 from 1

Material number: 4472.098.014

Plant: 446117304750

Material-assembly-group-no: 4461.173.047



MS-E 3060 /
DIFFERENTIAL

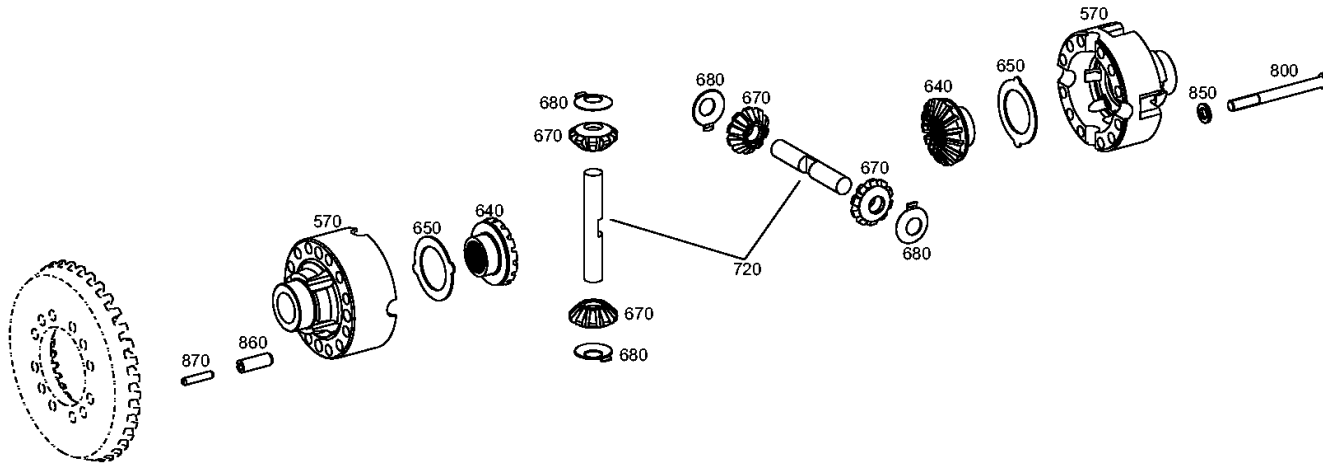

Plant

Page 1 from 1

Material number: 4472.098.014

Plant: 447212600200

Material-assembly-group-no: 4472.126.002



MS-E 3060 /
AXLE CASING

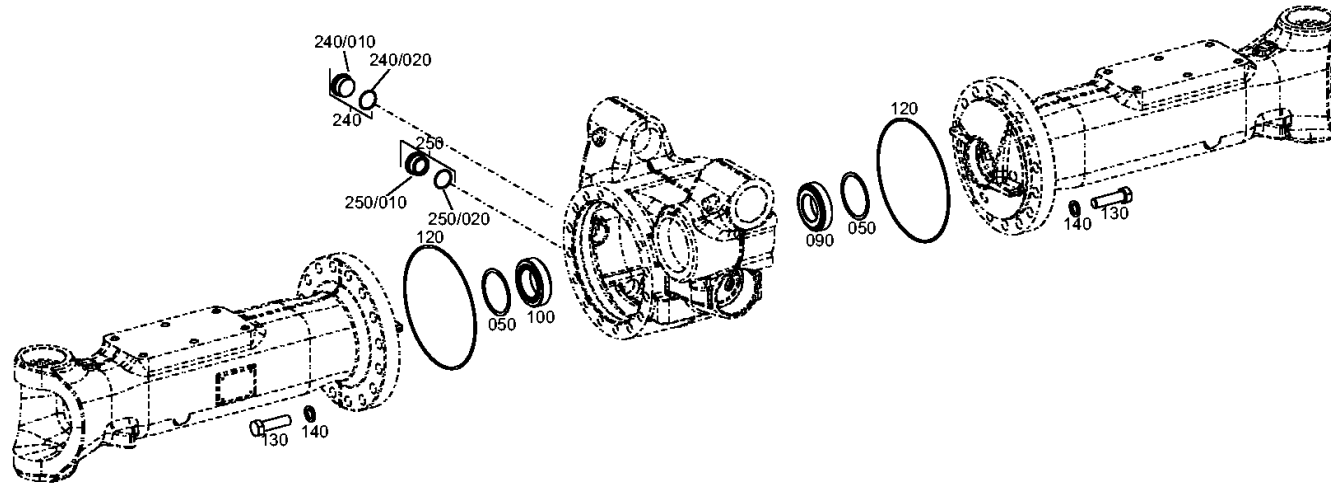

Plant

Page 1 from 1

Material number: 4472.098.014

Plant: 447212640900

Material-assembly-group-no: 4472.126.409



MS-E 3060 /
AXLE CASING

4472 126 409 00

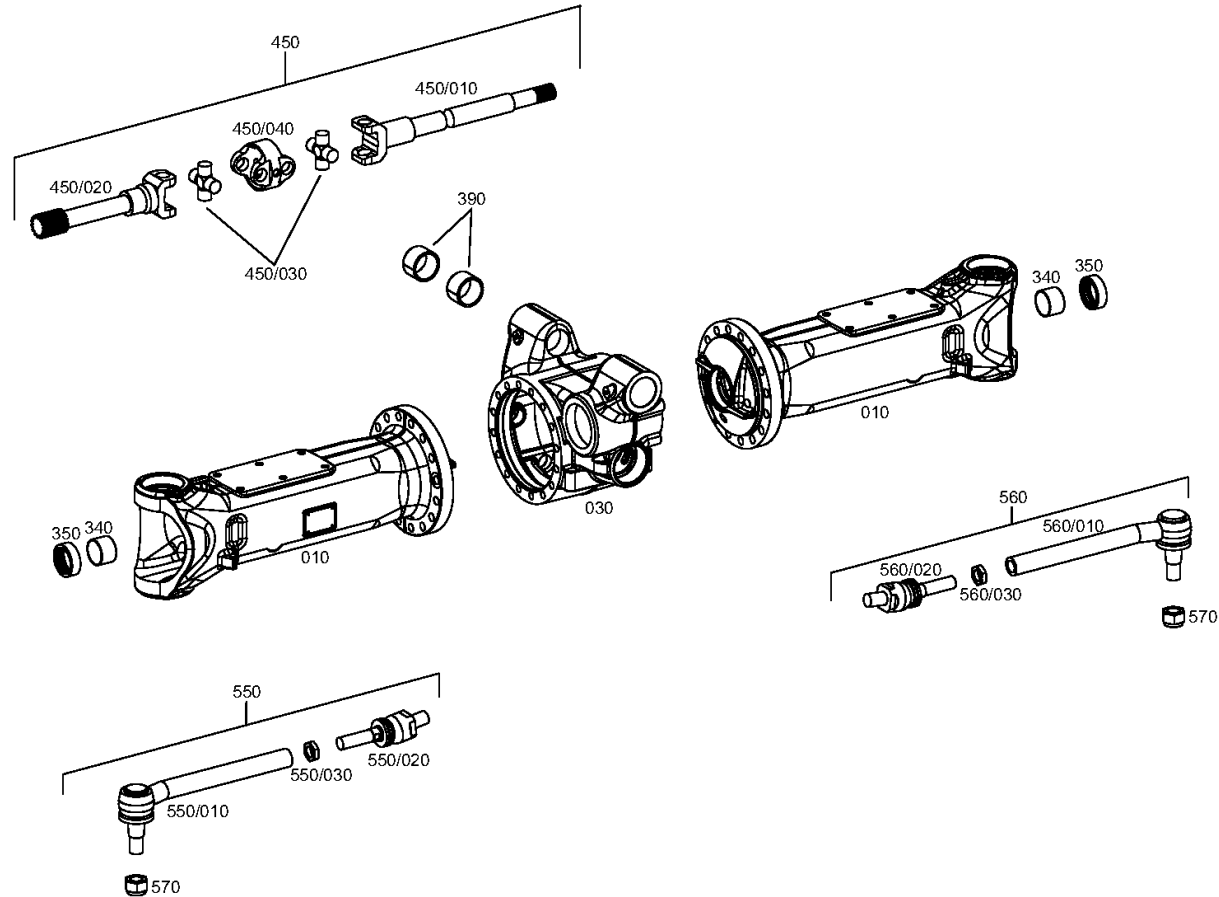

Plant

Page 1 from 1

Material number: 4472.098.014

Plant: 447212800600

Material-assembly-group-no: 4472.128.006



MS-E 3060 /
JOINT HOUSING

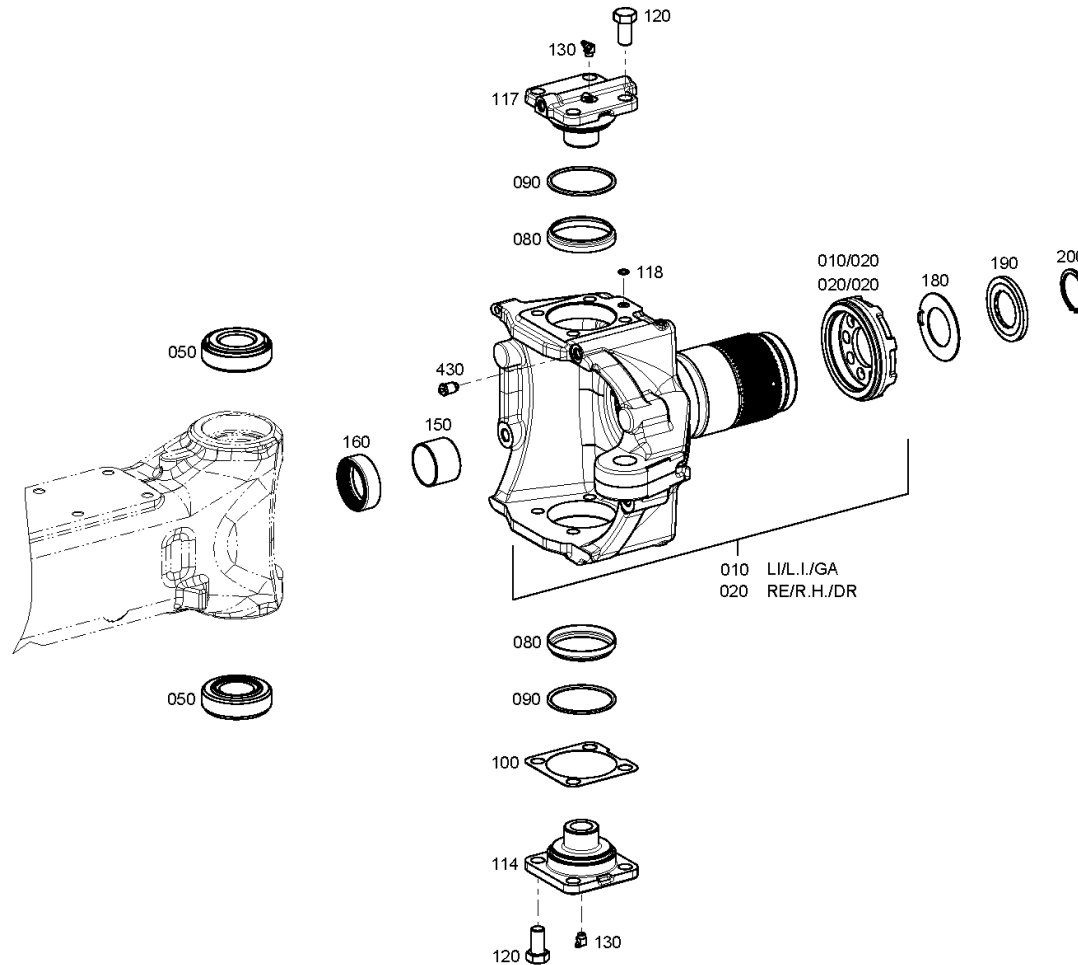

Plant

Page 1 from 1

Material number: 4472.098.014

Plant: 447212840100

Material-assembly-group-no: 4472.128.401



MS-E 3060 /
JOINT HOUSING

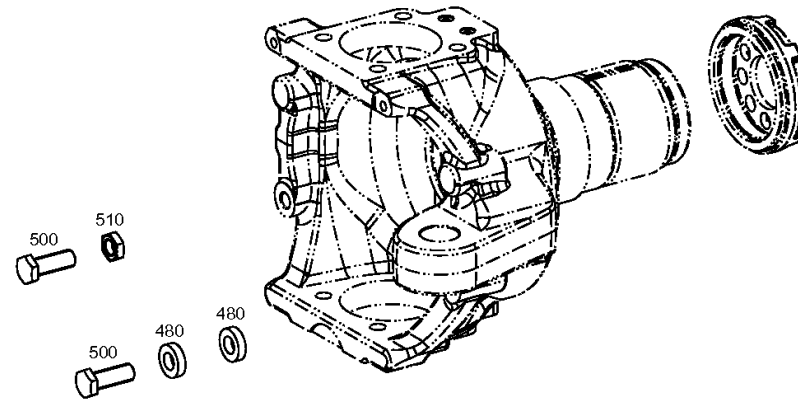

Plant

Page 1 from 1

Material number: 4472.098.014

Plant: 447213400200

Material-assembly-group-no: 4472.134.002



MS-E 3060 /
STEERING

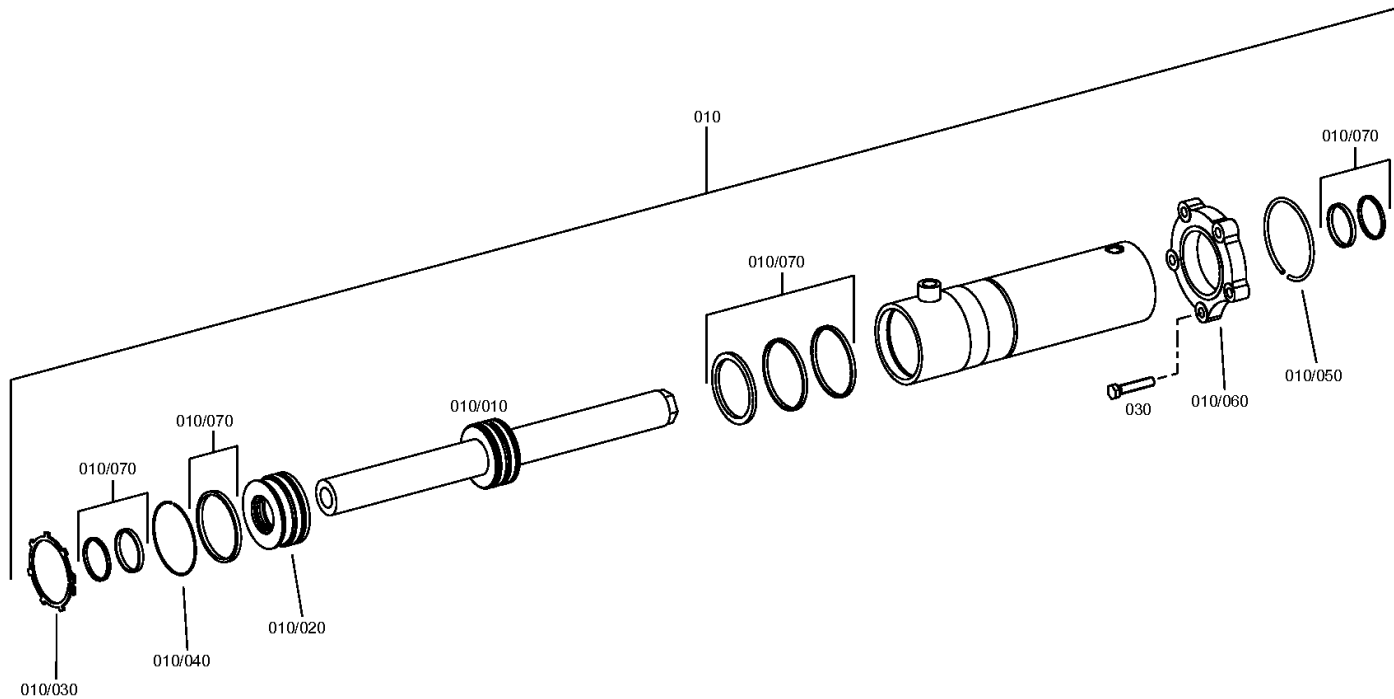

Plant

Page 1 from 1

Material number: 4472.098.014

Plant: 447213301100

Material-assembly-group-no: 4472.133.011



MS-E 3060 /
OUTPUT

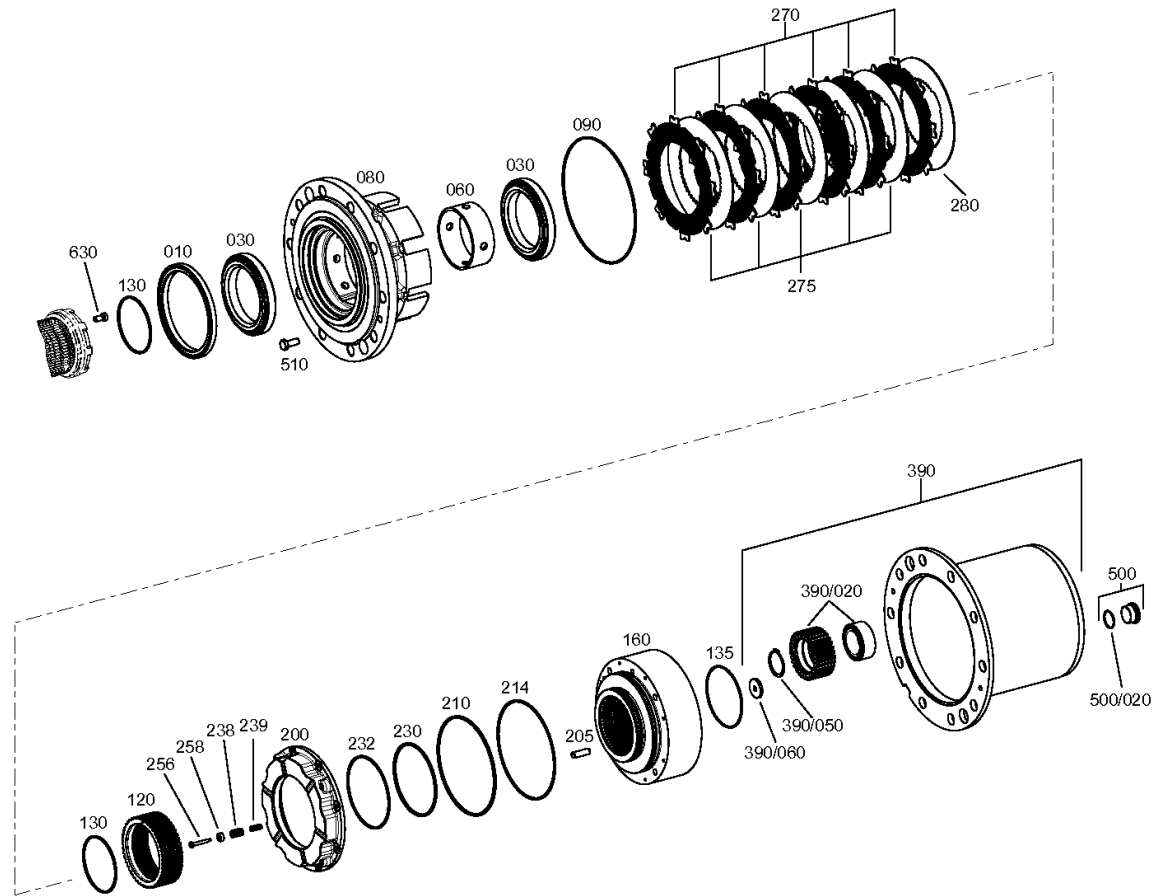

Plant

Page 1 from 1

Material number: 4472.098.014

Plant: 447213340100

Material-assembly-group-no: 4472.133.401



MS-E 3060 /
OUTPUT

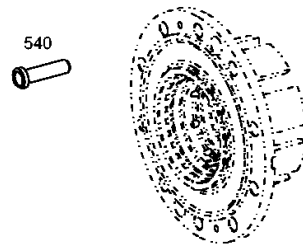

Plant

Page 1 from 1

Material number: 4472.098.014

Plant: 414313900100

Material-assembly-group-no: 4143.139.001



MS-E 3060 /
TYPE PLATE

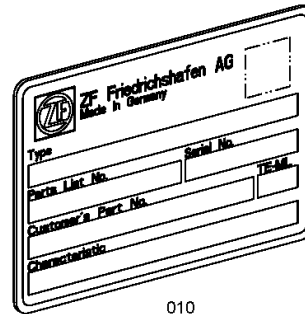

010

Plant

Page 1 from 1

Material number: 4472.098.014

Plant: 447229816000

Material-assembly-group-no: 4472.298.160



MS-E 3060 /
JOINT HOUSING

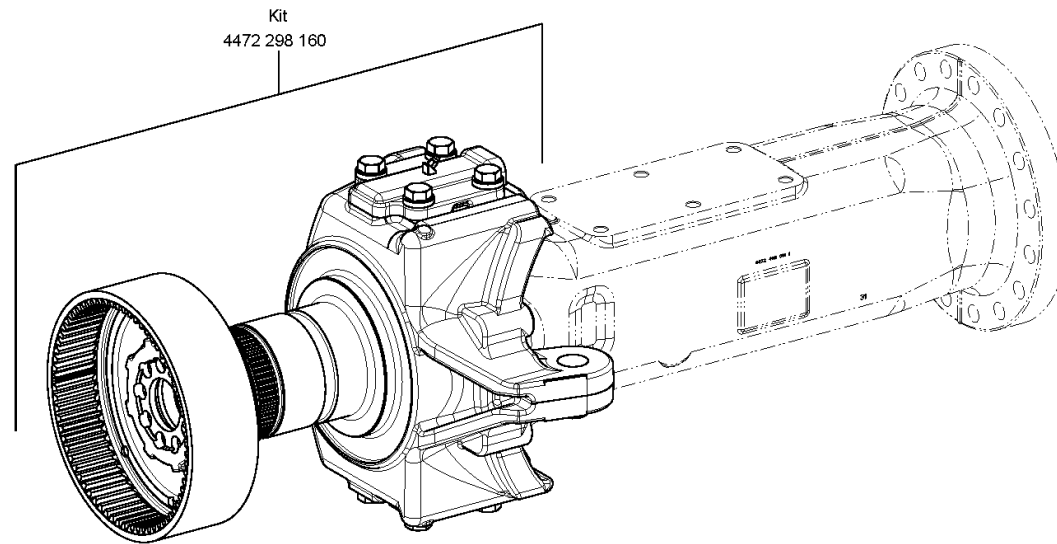

Plant

Page 1 from 1

Material number: 4472.098.014

Plant: 447229816100

Material-assembly-group-no: 4472.298.161



MS-E 3060 /
JOINT HOUSING

