



Spare Parts Catalog

MS-E 3070

Material number: 4472.099.003

Current date: 04.04.2018

ZF Friedrichshafen AG
Hauptverwaltung
80038 Friedrichshafen
Deutschland

Telefon: +49 7541 77-0

Telefax: +49 7541 77-908000

www.zf.com

zuständiges Werk:
Passau

Notes relating to the spare parts catalog

Setup of the spare parts catalog

- Cover sheet
- Technical Cover (only in SDM print)
- Overview of figures
- Figure
- Associated parts list
- Next figure
- Associated parts list
- ...

Figure and parts list



Overview of figures

Bildtafel Figure	Sachnummer Product number	Benennung (Description)	Technische Info Technical info	Description (Benennung)	Menge Quantity	Einheit Unit
068.08.17	1316.170.001	AUSLEGER	WL	SHIFT TURRET	1	Stk
068.08.06	1316.170.031	DECKEL	WL*H-H *VM	COVER	1	Stk
068.08.14	1316.170.808	DECKEL	WL*AUSL+GEH*H-H*HF160N	COVER	1	Stk
08	1316.170.441	ANSCHLUSSTEILE	WL*NG-VORB*RG-SCHL*168N *BAJONETT	CONNECTING PARTS	1	Stk

The "gap" indicates that there is no separate graphics panel (poster) for this assembly
The parts of this assembly are shown with the same mid-section number on the figure

1 Positions and subpositions

Pos.	Sachnummer Product number	Benennung (Description)	Technische Info Technical info	Description (Benennung)	Menge Quantity	Einheit Unit
0370	1315.201.054	RUECKLAUFBOLZEN	KPL.16S151*SG*L= 79	REV.IDLER SHAFT	1	Stk
/0120	0631.329.293	SPANNSTIFT		SLOT. PIN	1	Stk

Positions marked with "/" are the individual items of a completion
For example: Position 0370 contains a centering pin with the position /0120

2 Combinations with standardized parts

Pos.	Sachnummer Product number	Benennung (Description)	Technische Info Technical info	Description (Benennung)	Menge Quantity	Einheit Unit
0630		VERSCHL.SCHR.		SCREW PLUG	1	Stk
	0636.302.067	VERSCHL.SCHR.		SCREW PLUG	1	Stk
	0634.801.249	DICHTRING	A 26 X 31	SEALING RING	1	Stk

The parts list shows the components included in the combination of standardized parts

3 Depiction of position/item number on the figure and in the parts list

01.620 - on the figure 01 relates to the assembly in which the position is included. Due to program-related reasons, it is shown on the figure.

0620 - in the parts list

Pos.	Sachnummer Product number	Benennung (Description)	Technische Info Technical info	Description (Benennung)	Menge Quantity	Einheit Unit
0620	0732.040.736	DRUCKFEDER		COMPRESSION SPRING	1	Stk

4 *-Positions

Positions marked with an * are optional i.e. inclusion in the parts list is not mandatory.
The following note is shown on the figure

je nach Stücklistenausführung
depending on spec. number
*
suivant la nomenclature
secondo la distinta base

5 Parts, dotted display

Parts with dotted display on the figure are only used for orientation of other parts

Technical Cover

Page 1 from 2

Material number: 4472.099.003



MS-E 3070 /

Pos.	Information	Amendment number
	KUNDE:DAEWOO	
	IDENT-NO.: WITHOUT	
	APPROVAL:	
	QUESTIONNAIRE:	
	WITHOUT	
	PROJEKT-NR.:	
	VEHICLE DATA:	
	T21W	
	MOTOR: HYDROMATIK A6VM 160	
	GETRIEBE: 2 HL-290	
	DUAL TIRES: DOUBLE	
	REIFEN: 10.00X20	
	R.DYN. 0,506 M	
	RIM PITCH CIRCLE DIA: 335 MM	
	ENDGESCHWINDIGK.: 35,0 KM/H	
	PRODUCT DESCRIPTION:	
	MOUNTING POSITION:FRONT AXLE	
	UEBERSETZUNG GES:I= 16,00	
	PLANETENTRIEB: I= 6,40 P3-245-45	
	KEGELTRIEB: I= 2,50 Z=35/14	
	BEFESTIGUNG: FEDERSPUR L=620/1100	
	FLANSCHMASS: L=1890	
	BRAKE:	
	LAM.BR.: HYDR: 155X235	
	LINING: 7	
	ARBEITSZYLINDER: INTEGRIERT/D=100X50/180 BAR	
	DIFF.CARRIER:	
	TYPE:	
	SENS OF ROTATION:CLOCKWISE	
	RING GEAR: SPIRAL DIRECTION LEFT	
	POSITION OF RING GEAR: LEFT	
	FLANGE CONN: AD=120 *LZ=8 * D=10,1	
	DIFFERENTIAL:	

Technical Cover

Page 2 from 2

Material number: 4472.099.003



MS-E 3070 /

Pos.	Information	Amendment number
	TYP/GROESSE: D 750	
	ACHSKEGELRADPROF:N 38X1,25	
	DRAWINGS:	
	SCHNITT: 4472 099 002 (0)	
	EINBAU: 4472 699 003(0)	
	PRUEFANWEISUNG: 4472 760 021	
	ASSEMBLY INSTRUCTION:	
	LENKEINSCHLAG: 35 GRAD -1 GRAD	
	VORSPUR: +/- 1MM BEI 330MM MESSSCHENKELLAENGE	
	RADBOLZEN MIT SCHUTZHUELSE VOR FARBE SCHUETZEN	
	KOLBENHUB 0,7 - 1,3 MM	
	AUXILIARY UNIT	
	OIL CAPACITY:	
	AXLE: CA. 9,50L	
	PLANETENTRIEB/JE:CA. 2,50L	
	GESAMT: CA. 14,50L	
	OIL FILLING: YES	
	OIL GRADE:SPECIFICATION TE ML 05 / AXLE	
	BRAKE CONTROL: ATF-OIL/MOTOROIL 10 W	
	GESAMT-TROCKENMASSE: 752KG	
	PRIME COAT: 5 BLACK RAL 9005	
	MISCELLANEOUS/REMARKS:	
	SWINGING AXLE SUSPENSION	
	TYPE/ SERIAL NUMBER/ PART LIST NUMBER AND	
	OIL SPECIFICATION IN NAME PLATE	

Assembly group overview

Page 1 from 1

Material number: 4472.099.003



MS-E 3070 /

Graphics	Pos.	Material number	Name	Quantity	Amend. no.	Techn. Info.
447212501600	10	4472.125.016	INPUT	1		
447212540100	20	4472.125.401	INPUT	1		
446115307500	30	4461.153.075	DIFFERENTIAL	1		
447212600800	70	4472.126.008	AXLE CASING	1		
447212641200	80	4472.126.412	AXLE CASING	1		
447212800900	90	4472.128.009	JOINT HOUSING	1		
447212840000	100	4472.128.400	JOINT HOUSING	1		
447213400600	150	4472.134.006	STEERING	1		
447213303900	130	4472.133.039	OUTPUT	1		
447213340400	140	4472.133.404	OUTPUT	1		
414313900100	900	4143.139.001	TYPE PLATE	1		

Plant

Page 1 from 1

Material number: 4472.099.003

Plant: 447212501600

Material-assembly-group-no: 4472.125.016



MS-E 3070 /
INPUT

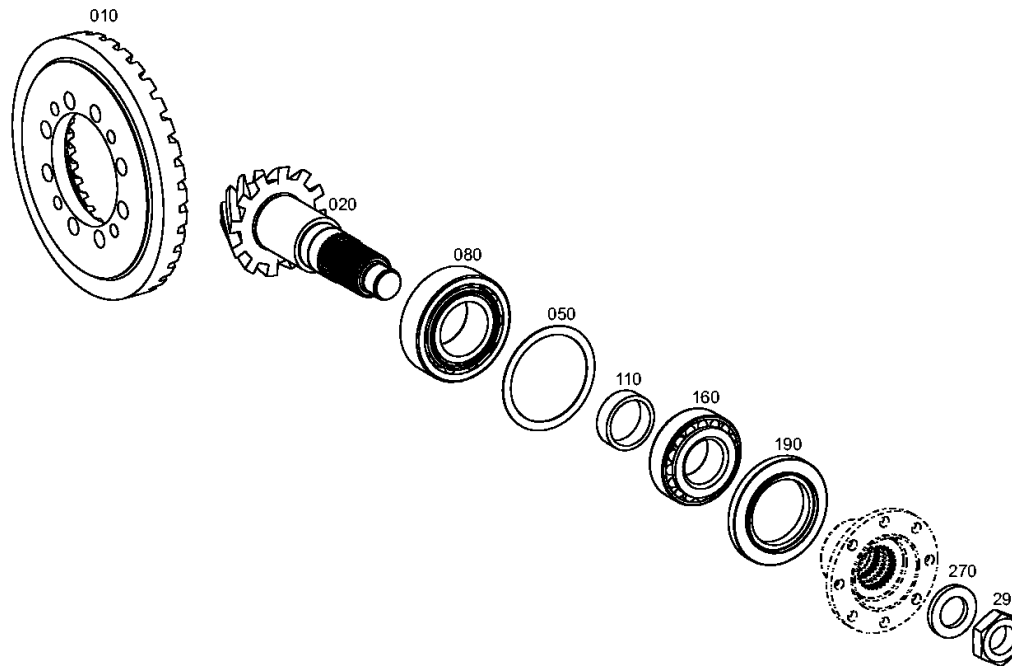

Plant

Page 1 from 1

Material number: 4472.099.003

Plant: 447212540100

Material-assembly-group-no: 4472.125.401



MS-E 3070 /
INPUT

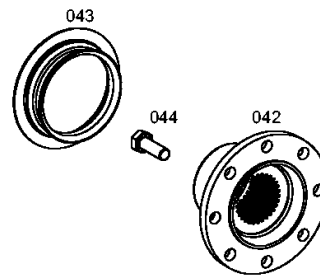

Plant

Page 1 from 1

Material number: 4472.099.003

Plant: 446115307500

Material-assembly-group-no: 4461.153.075



MS-E 3070 /
DIFFERENTIAL

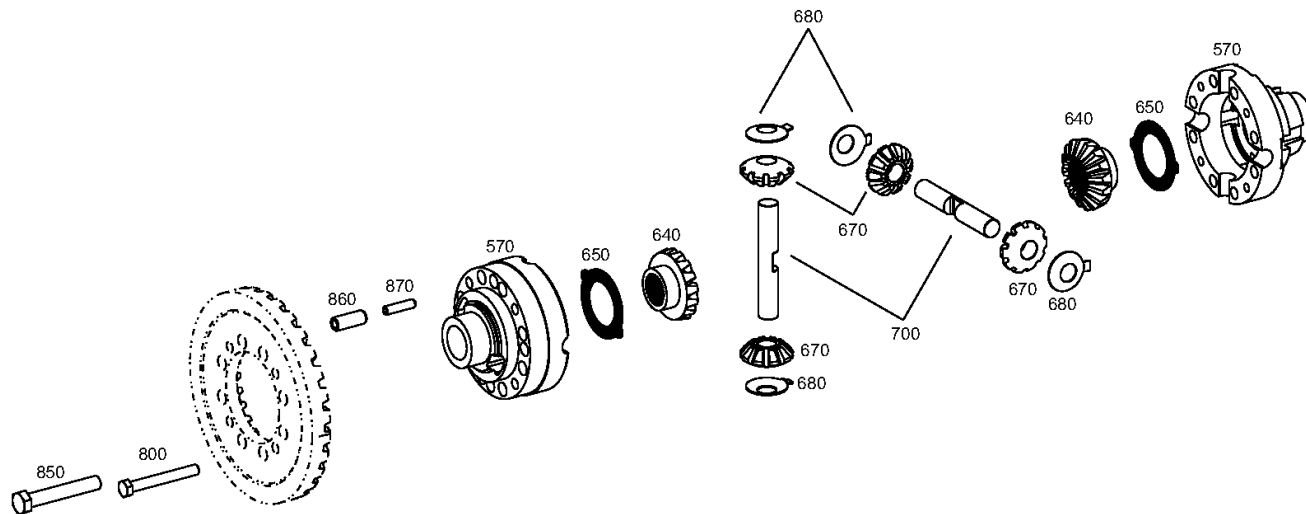

Plant

Page 1 from 1

Material number: 4472.099.003

Plant: 447212600800

Material-assembly-group-no: 4472.126.008



MS-E 3070 /
AXLE CASING

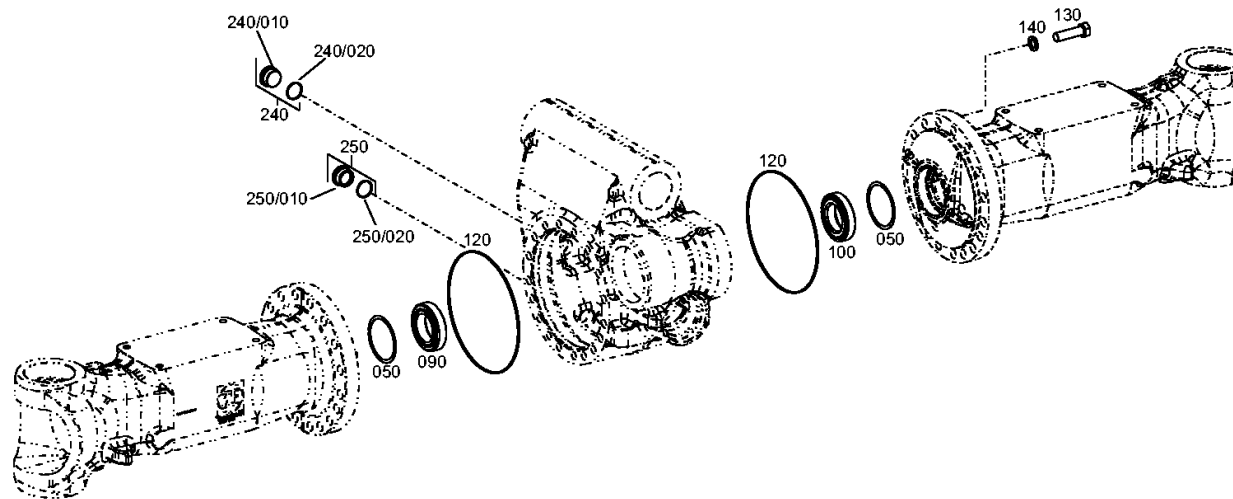

Plant

Page 1 from 1

Material number: 4472.099.003

Plant: 447212641200

Material-assembly-group-no: 4472.126.412



MS-E 3070 /
AXLE CASING

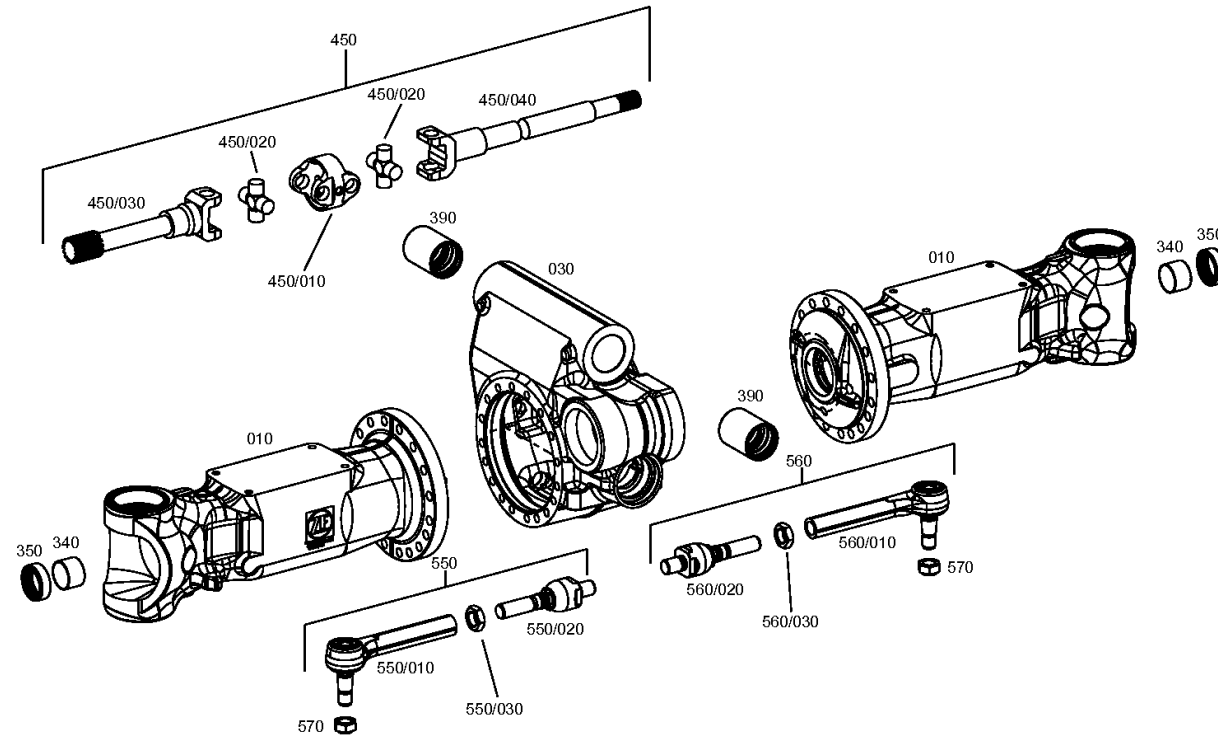

Plant

Page 1 from 1

Material number: 4472.099.003

Plant: 447212800900

Material-assembly-group-no: 4472.128.009



MS-E 3070 /
JOINT HOUSING

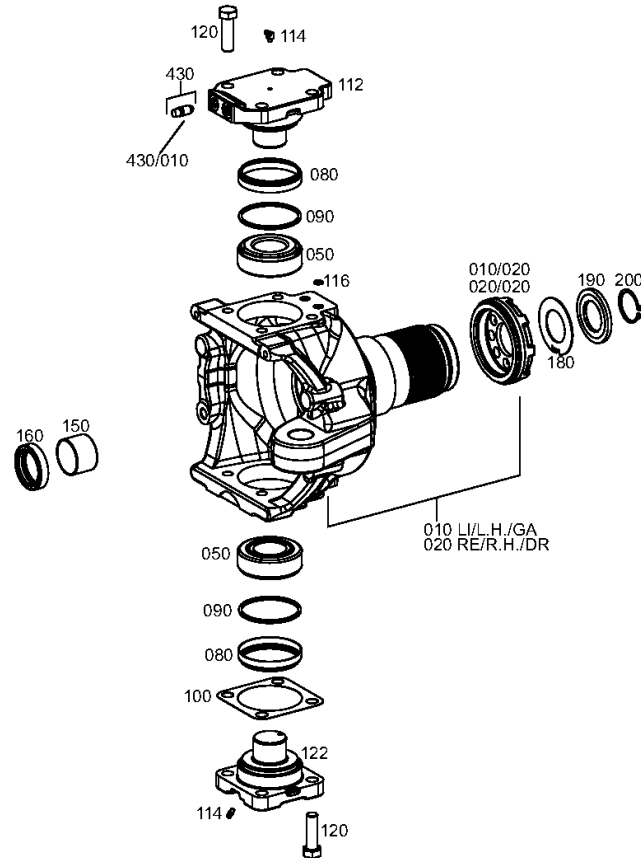

Plant

Page 1 from 1

Material number: 4472.099.003

Plant: 447212840000

Material-assembly-group-no: 4472.128.400



MS-E 3070 /
JOINT HOUSING

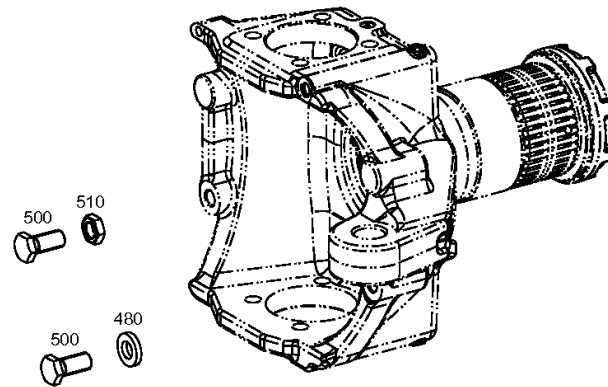

Plant

Page 1 from 1

Material number: 4472.099.003

Plant: 447213400600

Material-assembly-group-no: 4472.134.006



MS-E 3070 /
STEERING

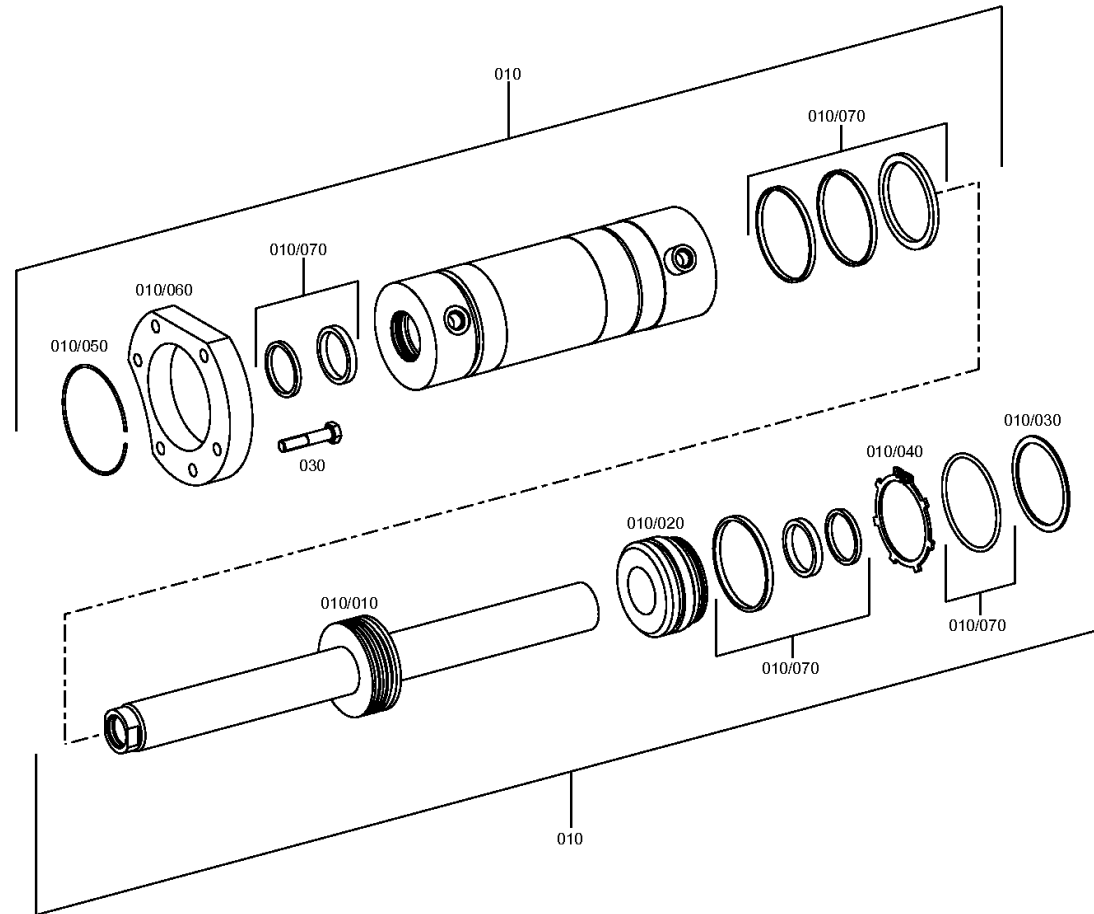

Plant

Page 1 from 1

Material number: 4472.099.003

Plant: 447213303900

Material-assembly-group-no: 4472.133.039



MS-E 3070 /
OUTPUT

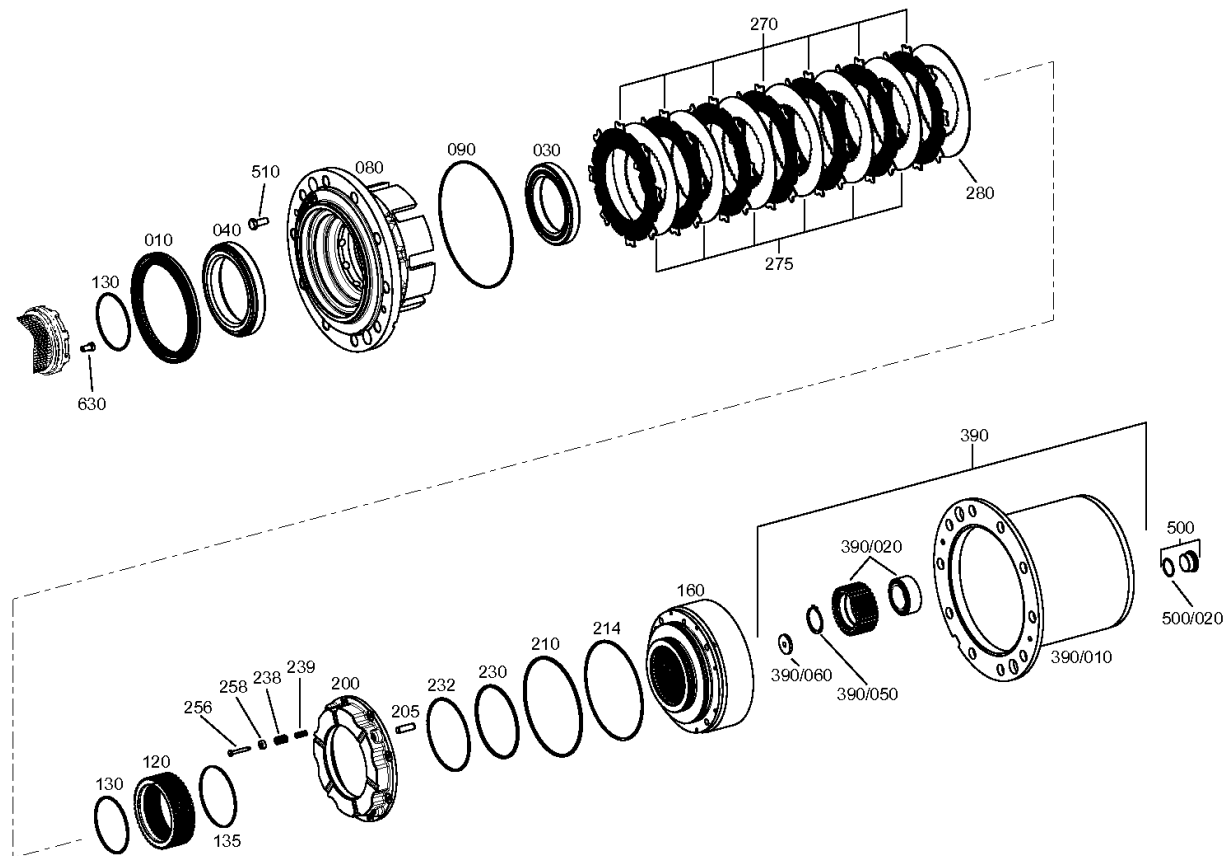

Plant

Page 1 from 1

Material number: 4472.099.003

Plant: 447213340400

Material-assembly-group-no: 4472.133.404



MS-E 3070 /
OUTPUT

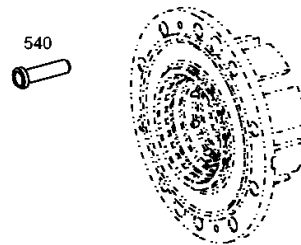

Plant

Page 1 from 1

Material number: 4472.099.003

Plant: 414313900100

Material-assembly-group-no: 4143.139.001



MS-E 3070 /
TYPE PLATE

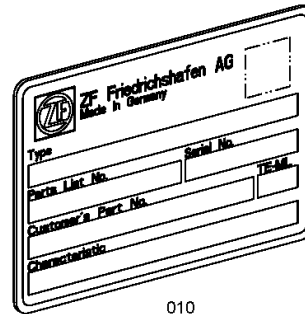

010