



Spare Parts Catalog

STARRACHSE

Material number: 4474.051.064

Current date: 21.04.2006

ZF Friedrichshafen AG

Hauptverwaltung

80038 Friedrichshafen

Deutschland

Telefon: +49 7541 77-0

Telefax: +49 7541 77-908000

www.zf.com

zuständiges Werk:

Passau

Notes relating to the spare parts catalog

Setup of the spare parts catalog

- Cover sheet
- Technical Cover (only in SDM print)
- Overview of figures
- Figure
- Associated parts list
- Next figure
- Associated parts list
- ...

Figure and parts list

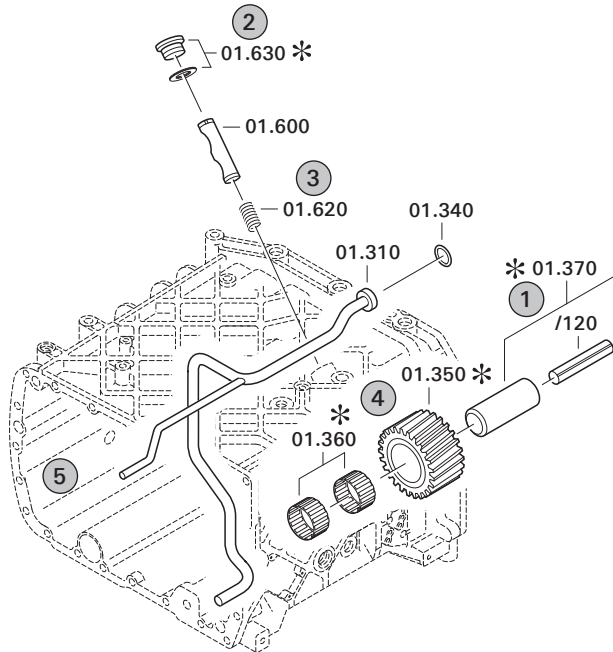

Overview of figures

Bildtafel Figure	Sachnummer Product number	Benennung (Description)	Technische Info Technical info	Description (Benennung)	Menge Quantity	Einheit Unit
068.08.17	1316.170.001	AUSLEGER	WL	SHIFT TURRET	1	Stk
068.08.06	1316.170.031	DECKEL	WL*H-H *VM	COVER	1	Stk
068.08.14	1316.170.808	DECKEL	WL*AUSL+GEH*H-H*HF160N	COVER	1	Stk
08	1316.170.441	ANSCHLUSSTEILE	WL*NG-VORB*RG-SCHL*168N *BAJONETT	CONNECTING PARTS	1	Stk

The "gap" indicates that there is no separate graphics panel (poster) for this assembly
The parts of this assembly are shown with the same mid-section number on the figure

1 Positions and subpositions

Pos.	Sachnummer Product number	Benennung (Description)	Technische Info Technical info	Description (Benennung)	Menge Quantity	Einheit Unit
0370	1315.201.054	RUECKLAUFBOLZEN	KPL.16S151*SG*L= 79	REV.IDLER SHAFT	1	Stk
/0120	0631.329.293	SPANNSTIFT		SLOT. PIN	1	Stk

Positions marked with "/" are the individual items of a completion
For example: Position 0370 contains a centering pin with the position /0120

2 Combinations with standardized parts

Pos.	Sachnummer Product number	Benennung (Description)	Technische Info Technical info	Description (Benennung)	Menge Quantity	Einheit Unit
0630		VERSCHL.SCHR.		SCREW PLUG	1	Stk
	0636.302.067	VERSCHL.SCHR.		SCREW PLUG	1	Stk
	0634.801.249	DICHTRING	A 26 X 31	SEALING RING	1	Stk

The parts list shows the components included in the combination of standardized parts

3 Depiction of position/item number on the figure and in the parts list

01.620 - on the figure 01 relates to the assembly in which the position is included. Due to program-related reasons, it is shown on the figure.

0620 - in the parts list

Pos.	Sachnummer Product number	Benennung (Description)	Technische Info Technical info	Description (Benennung)	Menge Quantity	Einheit Unit
0620	0732.040.736	DRUCKFEDER		COMPRESSION SPRING	1	Stk

4 *-Positions

Positions marked with an * are optional i.e. inclusion in the parts list is not mandatory.
The following note is shown on the figure

je nach Stücklistenausführung
depending on spec. number
*
suivant la nomenclature
secondo la distinta base

5 Parts, dotted display

Parts with dotted display on the figure are only used for orientation of other parts

Technical Cover

Page 1 from 2

Material number: 4474.051.064



STARRACHSE /

Pos.	Information	Amendment number
	KUNDE:CASE	
	IDENT-NR:873 612 14	
	QUESTIONNAIRE:	
	PROJEKT-NR.: 47082	
	VEHICLE DATA:	
	RADLADER 721 C	
	MOTOR: NEF 6NSTAA 4V	
	MOTORLEISTUNG: P=128 KW BEI N=2000 UPM	
	DREHMOMENT: T= 800 NM BEI P=1400 UPM	
	GETRIEBE: 4WG-190	
	TYRES: SINGLE	
	TYRES: 20.5-25	
	RIM PITCH CIRCLE DIA: 425 MM	
	AXLE ARRANGEMENT: REAR AXLE	
	UEBERSETZUNG GES:I= 20,36	
	PLANETENTRIEB: I= 6,40 P4-285-50	
	KEGELTRIEB: I= 3,18 Z=35/11	
	MOUNTING: SUSPENSION MID POSITION	
	FLANGE DISTANCE: L=2083	
	SPURWEITE: L=2064	
	BRAKE:	
	MULTI-DISC BRAKE:HYDRAULIC 345X264	
	LINED DISC: 4 PIECES	
	INPUT:	
	TYPE: CK	
	SENS OF ROTATION:COUNTER CLOCKWISE	
	RING GEAR: SPIRAL DIRECTION LEFT	
	FLANGE POS.BEVEL DRIVE: MIDDLE	
	FLANGE DANA 1550	
	LIMITED-SLIP DIFFERENTIAL	
	TYPE: DL 1200	
	BEVEL SIDE GEAR SPLINE: N 42X1,25	
	BLOCKAGE EFFECT: 45%	

Technical Cover

Page 2 from 2

Material number: 4474.051.064



STARRACHSE /

Pos.	Information	Amendment number
	DRAWINGS:	
	SECT.DRAWING:4474 051 002 (0)	
	EINBAU: 4474 651 069(O)	
	TEST INSTRUCT.: 4474 760 004 (3)	
	TEST INSTRUCT. 4474 760 005(2)	
	ASSEMBLY INSTRUCTION:	
	AUTOMATIC BRAKE ADJUSTING DEVICE	
	AXIAL PLAY SUN 0,5 - 2,0 MM	
	OIL CAPACITY:	
	TOTAL: 27,00L	
	OIL FILLING: YES	
	OEL SPECIFICATION:TE ML 05	
	BRAKE CONTROL: ATF-OIL/MOTOROIL 10 W	
	WEIGHT: 662KG	
	COLOR: 2 YELLOW RAL 1006	
	PACKING:	
	MISCELLANEOUS/REMARKS:	
	PUNCH-MARK THE QUANTITY OF LINED DISC AT TYPE PLATE	
	JINMYUNG ZYLINDERROLLEN	
	*	

Assembly group overview

Page 1 from 1

Material number: 4474.051.064



STARRACHSE /

Picture	Pos.	Material number	Name	Quantity	Amend. no.	Techn. Info.
446000601601	10	4460.006.038	CK	1		
447414504700	20	4474.145.047	AXLE CASING	1		
447414545000	30	4474.145.450	AXLE CASING	1		
447414606501	40	4474.146.065	OUTPUT	2		
447414700201	60	4474.147.008	BRAKE	2		

Picture

Page 1 from 2

Material number: 4474.051.064

Picture: 446000601601

Material-assembly-group-no: 4460.006.038



STARRACHSE /
CK

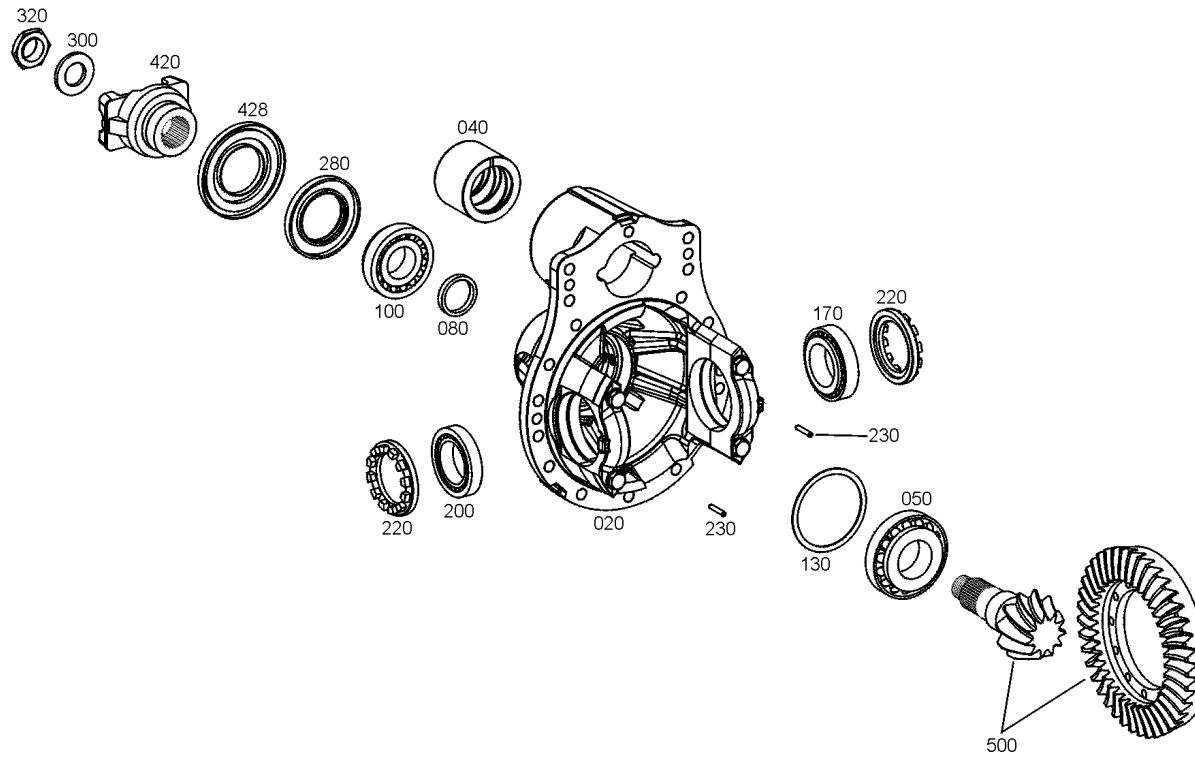

Picture

Page 2 from 2

Material number: 4474.051.064

Picture: 446000601602

Material-assembly-group-no: 4460.006.038



STARRACHSE /
CK

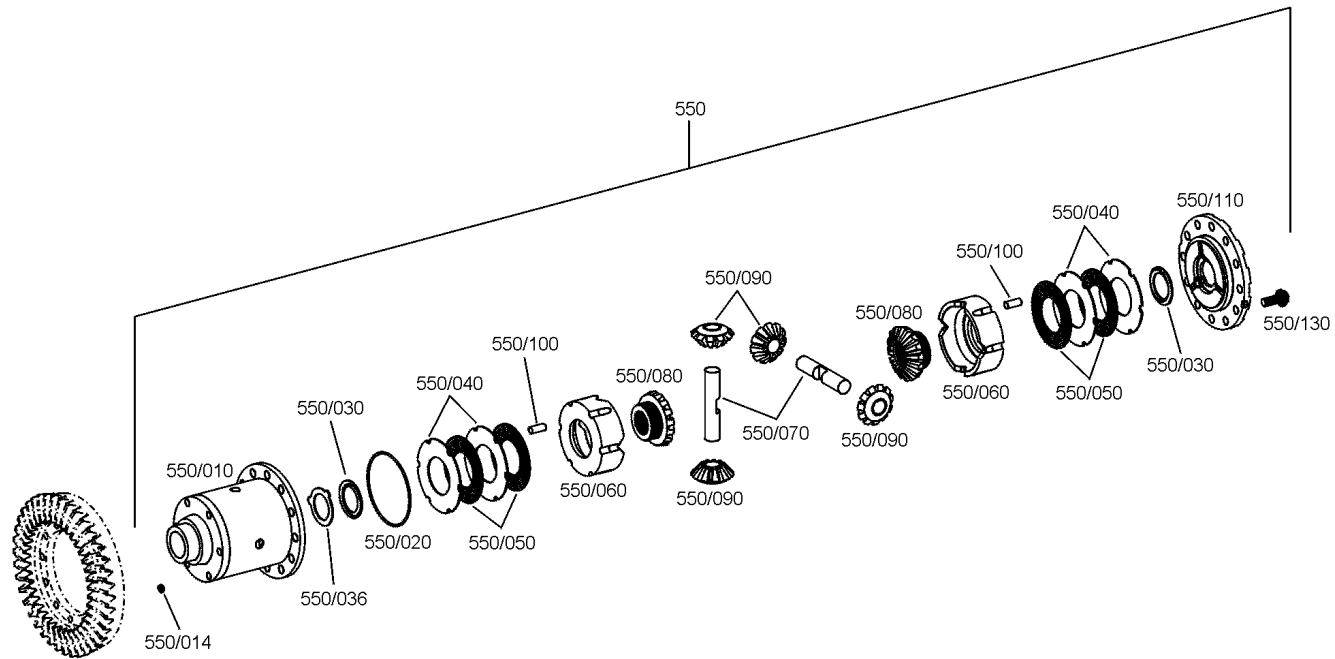

Picture

Page 1 from 1

Material number: 4474.051.064

Picture: 447414504700

Material-assembly-group-no: 4474.145.047



STARRACHSE /
AXLE CASING

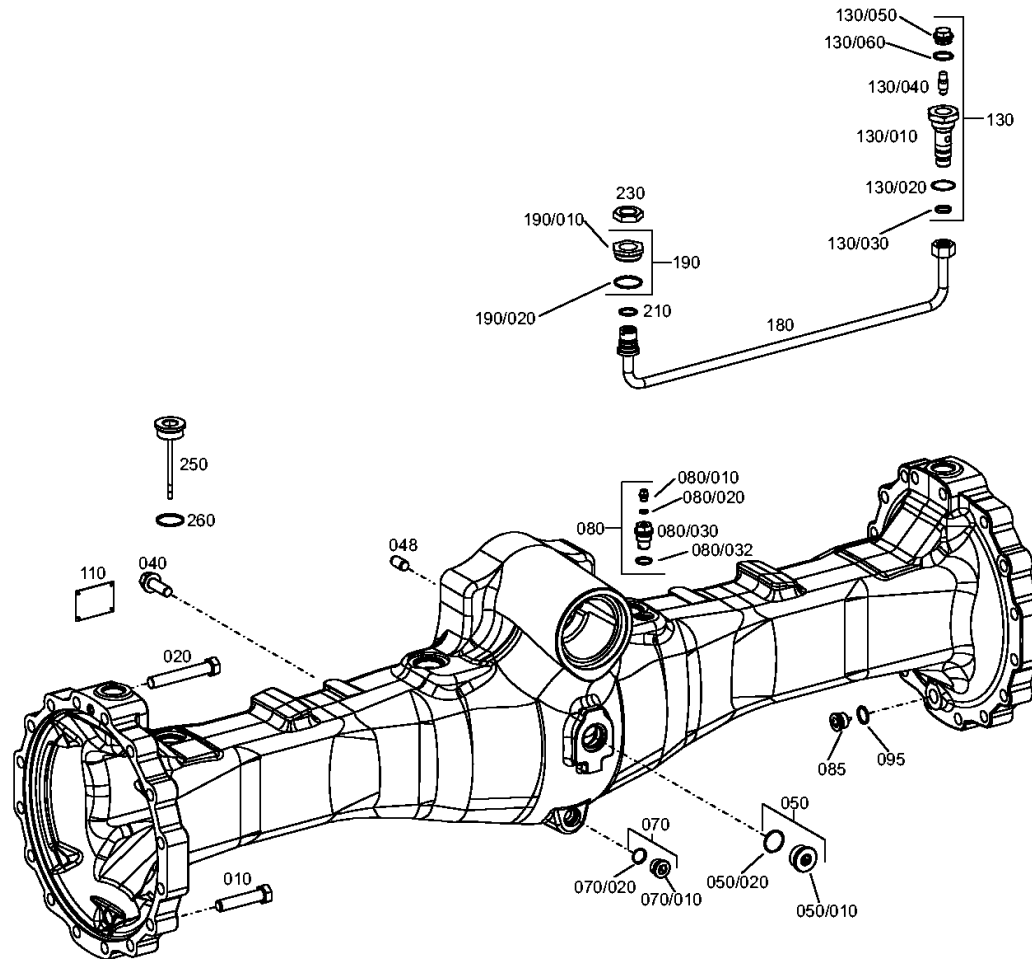

Picture

Page 1 from 1

Material number: 4474.051.064

Picture: 447414545000

Material-assembly-group-no: 4474.145.450



STARRACHSE /
AXLE CASING

