



Spare Parts Catalog

AS 2045

Material number: 4475.006.052

Current date: 05.05.2021

ZF Friedrichshafen AG
Hauptverwaltung
80038 Friedrichshafen
Deutschland

Telefon: +49 7541 77-0

Telefax: +49 7541 77-908000

www.zf.com

zuständiges Werk:
Passau

Notes relating to the spare parts catalog

Setup of the spare parts catalog

- Cover sheet
- Technical Cover (only in SDM print)
- Overview of figures
- Figure
- Associated parts list
- Next figure
- Associated parts list
- ...

Figure and parts list



Overview of figures

Bildtafel Figure	Sachnummer Product number	Benennung (Description)	Technische Info Technical info	Description (Benennung)	Menge Quantity	Einheit Unit
068.08.17	1316.170.001	AUSLEGER	WL	SHIFT TURRET	1	Stk
068.08.06	1316.170.031	DECKEL	WL*H-H *VM	COVER	1	Stk
068.08.14	1316.170.808	DECKEL	WL*AUSL+GEH*H-H*HF160N	COVER	1	Stk
08	1316.170.441	ANSCHLUSSTEILE	WL*NG-VORB*RG-SCHL*168N *BAJONETT	CONNECTING PARTS	1	Stk

The "gap" indicates that there is no separate graphics panel (poster) for this assembly
The parts of this assembly are shown with the same mid-section number on the figure

1 Positions and subpositions

Pos.	Sachnummer Product number	Benennung (Description)	Technische Info Technical info	Description (Benennung)	Menge Quantity	Einheit Unit
0370	1315.201.054	RUECKLAUFBOLZEN	KPL.16S151*SG*L= 79	REV.IDLER SHAFT	1	Stk
/0120	0631.329.293	SPANNSTIFT		SLOT. PIN	1	Stk

Positions marked with "/" are the individual items of a completion
For example: Position 0370 contains a centering pin with the position /0120

2 Combinations with standardized parts

Pos.	Sachnummer Product number	Benennung (Description)	Technische Info Technical info	Description (Benennung)	Menge Quantity	Einheit Unit
0630		VERSCHL.SCHR.		SCREW PLUG	1	Stk
	0636.302.067	VERSCHL.SCHR.		SCREW PLUG	1	Stk
	0634.801.249	DICHTRING	A 26 X 31	SEALING RING	1	Stk

The parts list shows the components included in the combination of standardized parts

3 Depiction of position/item number on the figure and in the parts list

01.620 - on the figure 01 relates to the assembly in which the position is included. Due to program-related reasons, it is shown on the figure.

0620 - in the parts list

Pos.	Sachnummer Product number	Benennung (Description)	Technische Info Technical info	Description (Benennung)	Menge Quantity	Einheit Unit
0620	0732.040.736	DRUCKFEDER		COMPRESSION SPRING	1	Stk

4 *-Positions

Positions marked with an * are optional i.e. inclusion in the parts list is not mandatory.
The following note is shown on the figure

je nach Stücklistenausführung
depending on spec. number
*
suivant la nomenclature
secondo la distinta base

5 Parts, dotted display

Parts with dotted display on the figure are only used for orientation of other parts

Technical Cover

Page 1 from 2

Material number: 4475.006.052



AS 2045 /

Pos.	Information	Amendment number
	KUNDE:DEUTZ FAHR(DF)	
	IDENT-NR:9.0441 9857 KY	
	QUESTIONNAIRE:	
	WITHOUT	
	PROJEKT-NR.:33941	
	VEHICLE DATA:	
	SCHLEPPER TM	
	MOTORLEISTUNG: P= 85 KW BEI N=2400 UPM	
	ENGINE POWER: P=107 KW IN N=2400 UPM	
	TYRES: SINGLE	
	TIRES:	
	RIM PITCH CIRCLE DIA: 275 MM	
	PRODUCT DESCRIPTION:	
	ANTRIEB:SEITLICH 45 MM	
	MOUNTING POSITION:FRONT AXLE	
	UEBERSETZUNG GES:I= 15,86	
	PLANETARY DRIVE: I= 6,00 P3-207-44	
	KEGELTRIEB: I= 2,64 Z=37/14	
	MOUNTING: SUSPENSION MID POSITION	
	FLANSCHMASS: L=1710	
	ARBEITSZYLINDER: INTEGRIERT/KARTUSCHE	
	INPUT:	
	TYPE: AE 400K	
	SENS OF ROTATION:CLOCKWISE	
	RING GEAR: SPIRAL DIRECTION RIGHT	
	FLANGE POSITION CONE-PULLEY-DRIVE: CENTER LEFT	
	FLANSCH AD=120 *LZ= 8 *D=M10,1	
	LIMITED-SLIP DIFFERENTIAL	
	TYP/GROESSE: DHL 400 MIT D 400	
	BEVEL SIDE GEAR SPLINE:N32X1,25	
	DRAWINGS:	
	SCHNITT: 4475 006 024(0)	
	EINBAU: 4475 606 023(0)	

Technical Cover

Page 2 from 2

Material number: 4475.006.052



AS 2045 /

Pos.	Information	Amendment number
	MONTAGEZCHNG:0899 501 685()	
	EINSTELL-VOR:4481 700 003()	
	TEST SPECIFICATION: 4475 760 003(2)	
	ASSEMBLY INSTRUCTION:	
	IDENT-NR.:0441 9857KY U.APL 2045 IN TYPENSCHILD PRAEGEN	
	POSITION OF RING GEAR: LEFT IN DIRECTION OF MOTION	
	RITZELEINSTELLMASS: 131,..	
	*	
	MONTAGEVORSCHR.-NABENDICHTUNG 4475 507 001	
	L.W.SENSOR FUNKTION PRUEF.S.SCHNITTZEICHNUNG	
	INSTRUCTION FEET AXLE LEG FICTION 4475 504 001	
	OIL CAPACITY:	
	ACHSBRUECKE: CA. 6,00L	
	PLANETARY DRIVE: (APPRX) 0,80L	
	GESAMT: CA. 7,60L	
	OIL FILLING: YES	
	OIL SPECIFICATION:SAE 90 LS SPEZ.MIL-L 2105 D	
	WEIGHT-TOTAL: ...KG	
	COLOUR: 5 BLACK RAL 9005	
	PACKING:	
	MISCELLANEOUS/REMARKS:	
	FEDERUNG	
	ZWEI LENKWINKELSENSOREN	
	*	

Assembly group overview

Page 1 from 1

Material number: 4475.006.052



AS 2045 /

Graphics	Pos.	Material number	Name	Quantity	Amend. no.	Techn. Info.
447510200201	10	4475.102.020	INPUT	1		
447510200202	20	4475.102.419	INPUT	1		
448117100100	30	4481.171.011	LIMIT.SLIP DIFF	1		
447510107701	70	4475.101.075	AXLE CASING	1		
447510107702	80	4475.101.516	AXLE CASING	1		
447510300201	90	4475.103.038	JOINT HOUSING	1		
447510300202	100	4475.103.417	JOINT HOUSING	1		
447510400200	110	4475.104.015	PLANETARY DRIVE	1		
447510500100	120	4475.105.041	STEERING	1		

Plant

Page 1 from 1

Material number: 4475.006.052

Plant: 447510200201

Material-assembly-group-no: 4475.102.020



AS 2045 /
INPUT

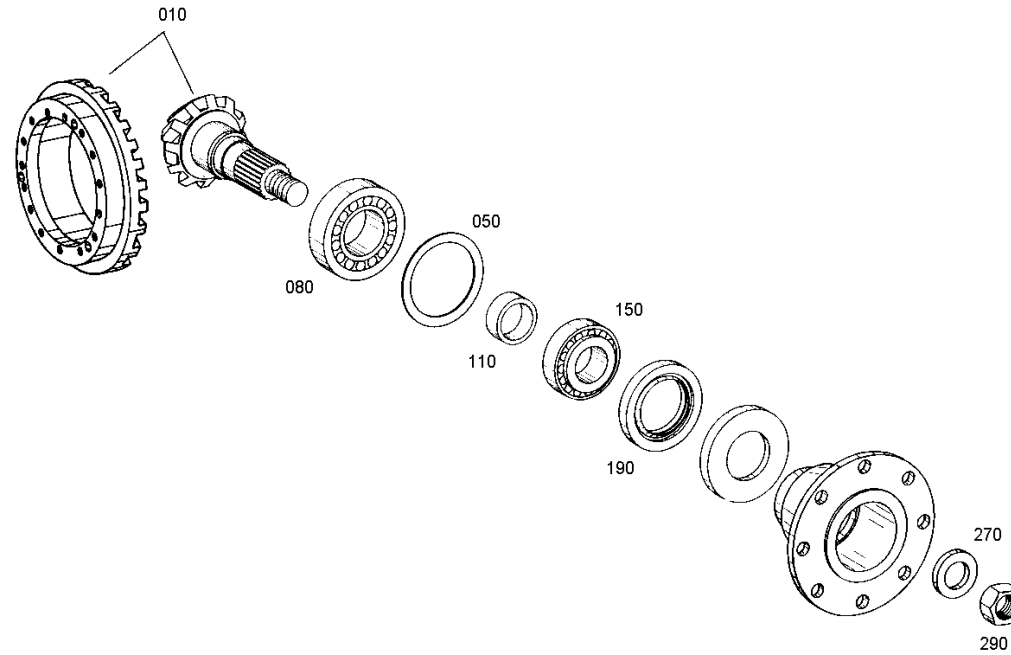

Plant

Page 1 from 1

Material number: 4475.006.052

Plant: 447510200202

Material-assembly-group-no: 4475.102.419



AS 2045 /
INPUT

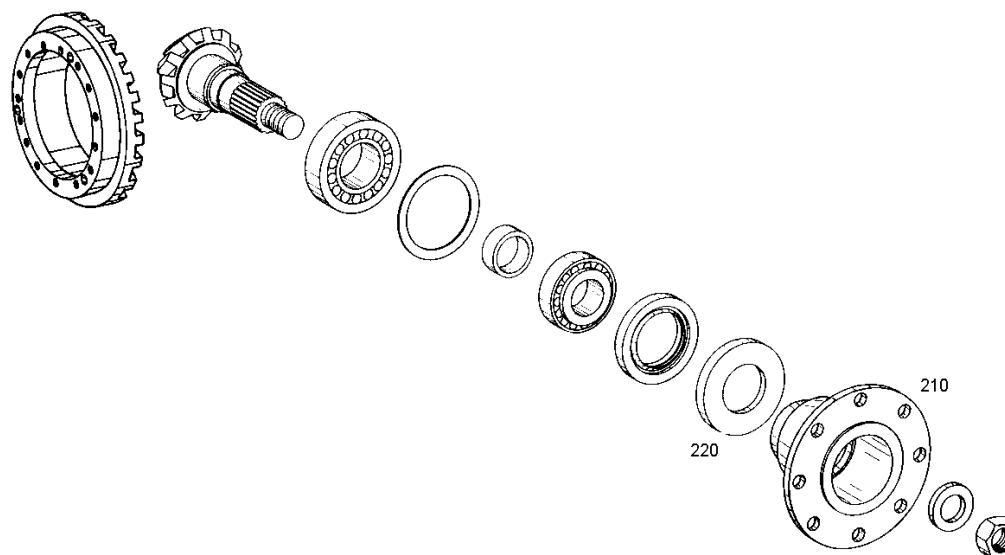

Plant

Page 1 from 1

Material number: 4475.006.052

Plant: 448117100100

Material-assembly-group-no: 4481.171.011



AS 2045 /
LIMIT.SLIP DIFF

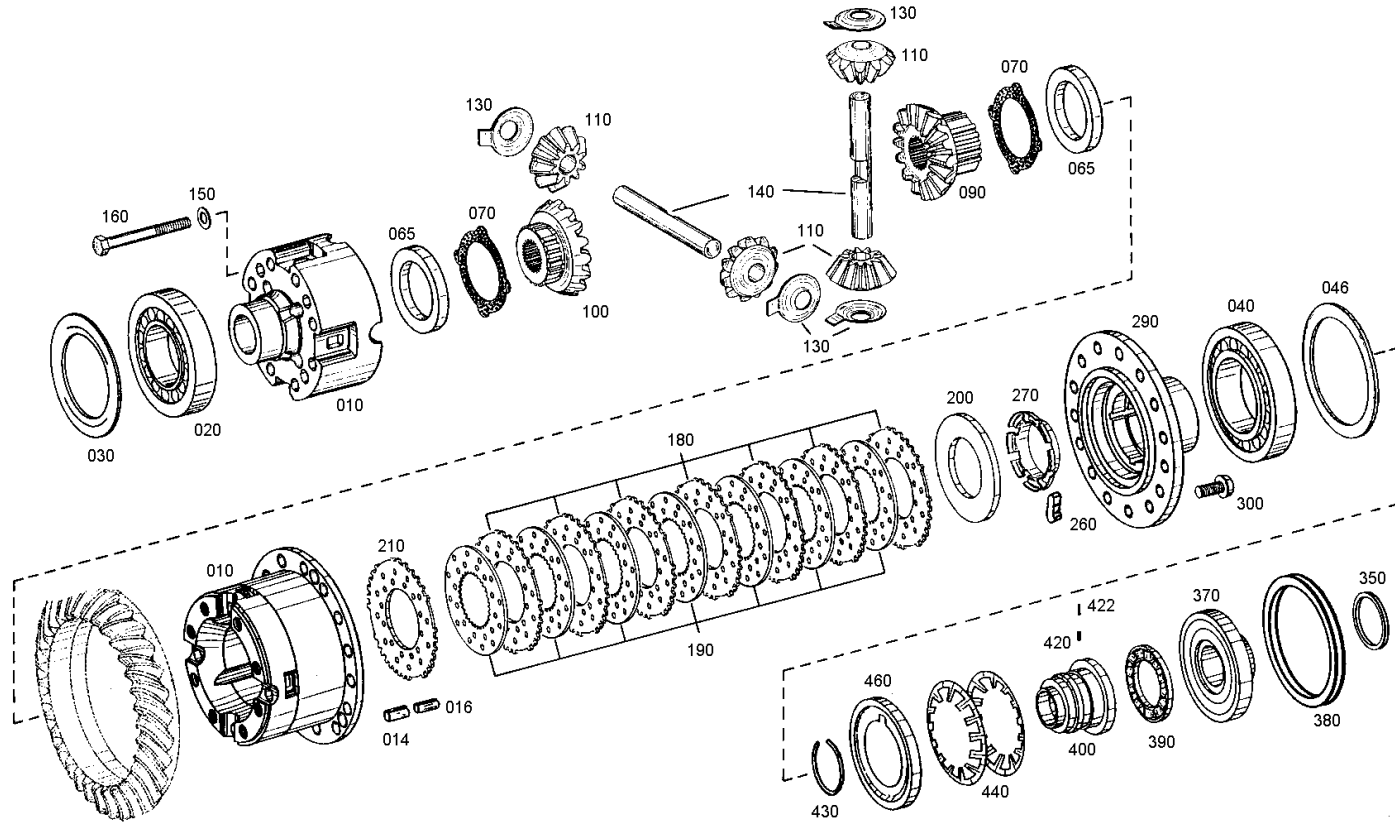

Plant

Page 1 from 1

Material number: 4475.006.052

Plant: 447510107701

Material-assembly-group-no: 4475.101.075



AS 2045 /
AXLE CASING

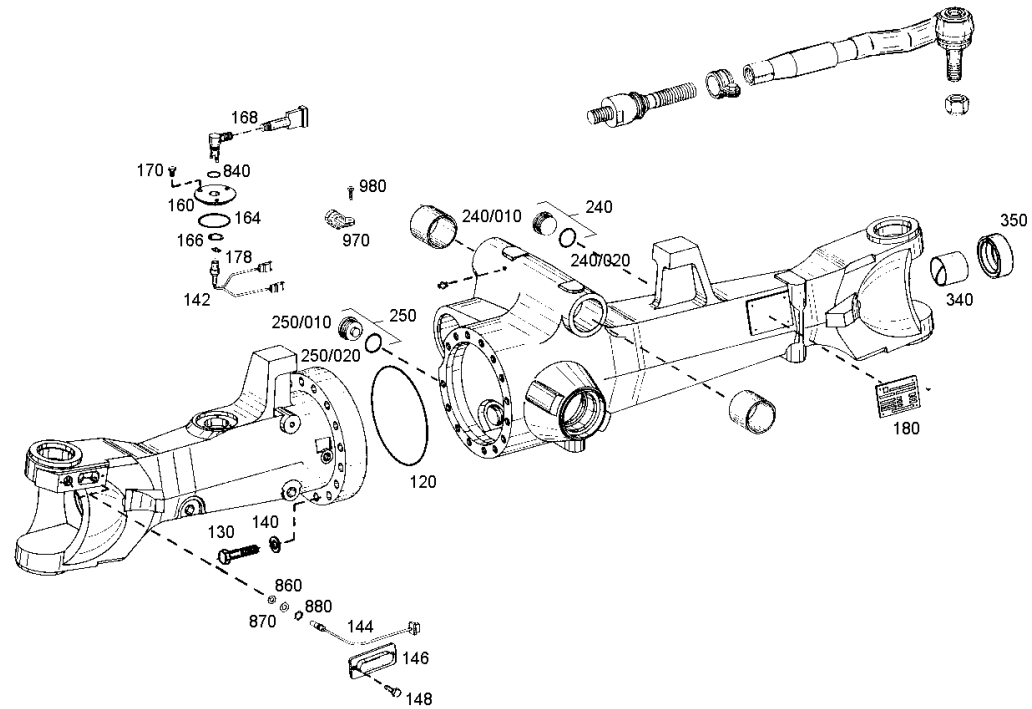

Plant

Page 1 from 1

Material number: 4475.006.052

Plant: 447510107702

Material-assembly-group-no: 4475.101.516



AS 2045 /
AXLE CASING

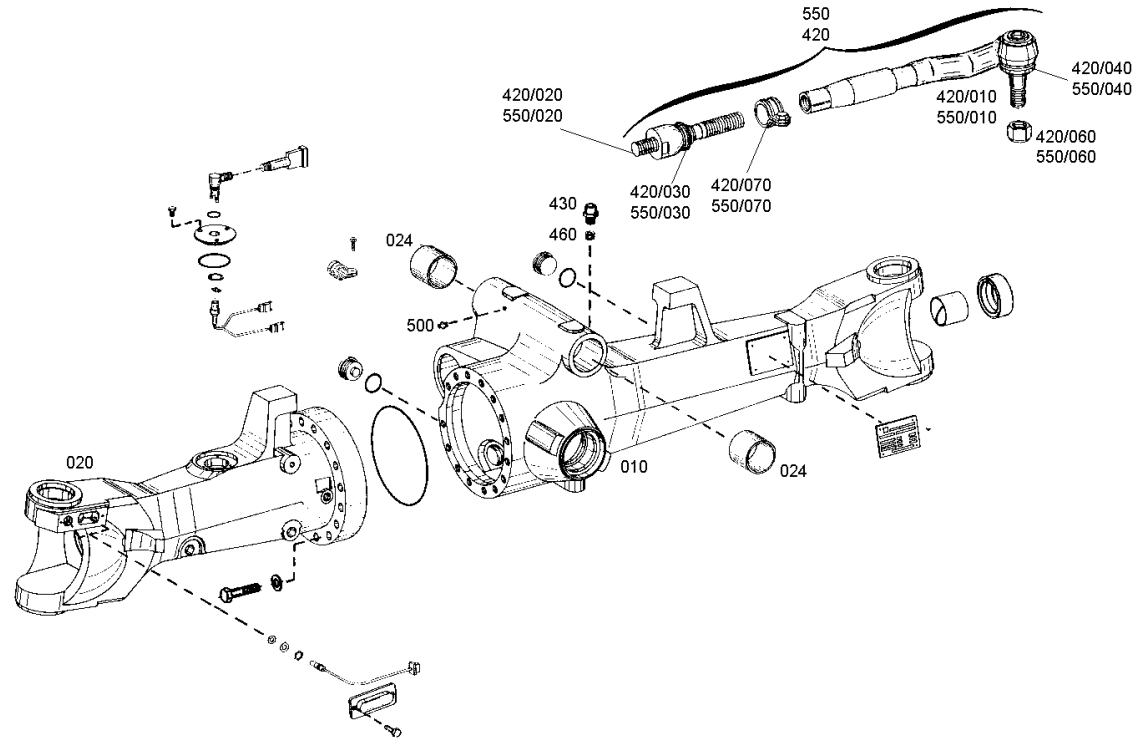

Plant

Page 1 from 1

Material number: 4475.006.052

Plant: 447510300201

Material-assembly-group-no: 4475.103.038



AS 2045 /
JOINT HOUSING

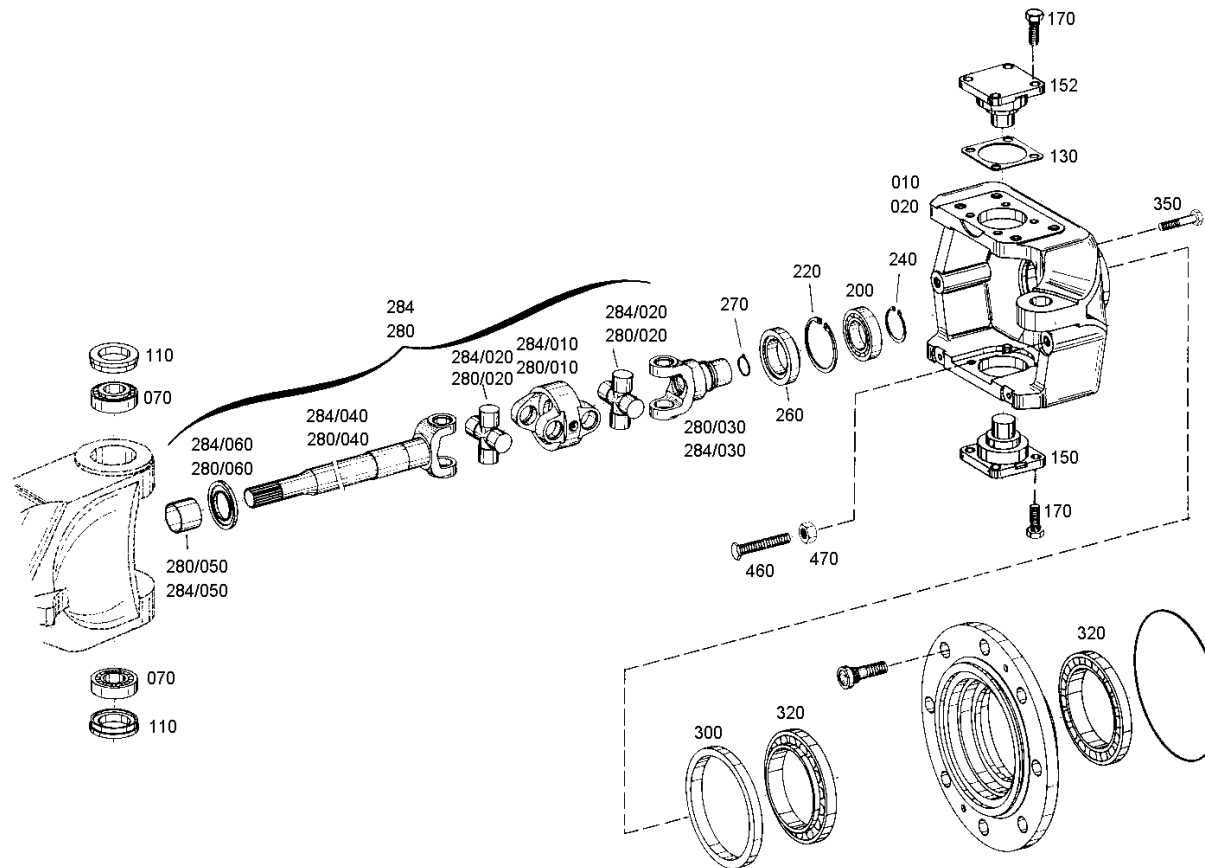

Plant

Page 1 from 1

Material number: 4475.006.052

Plant: 447510300202

Material-assembly-group-no: 4475.103.417



AS 2045 /
JOINT HOUSING

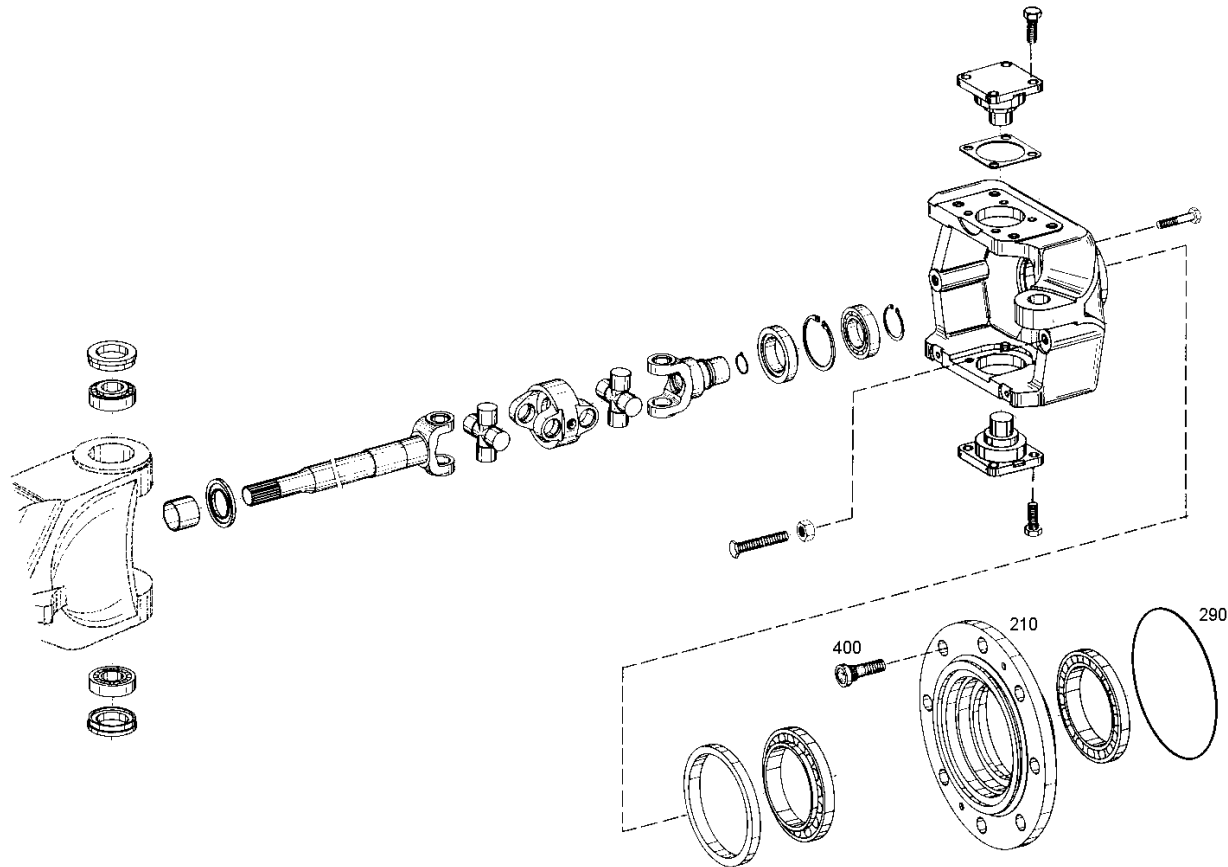

Plant

Page 1 from 1

Material number: 4475.006.052

Plant: 447510400200

Material-assembly-group-no: 4475.104.015



AS 2045 /
PLANETARY DRIVE

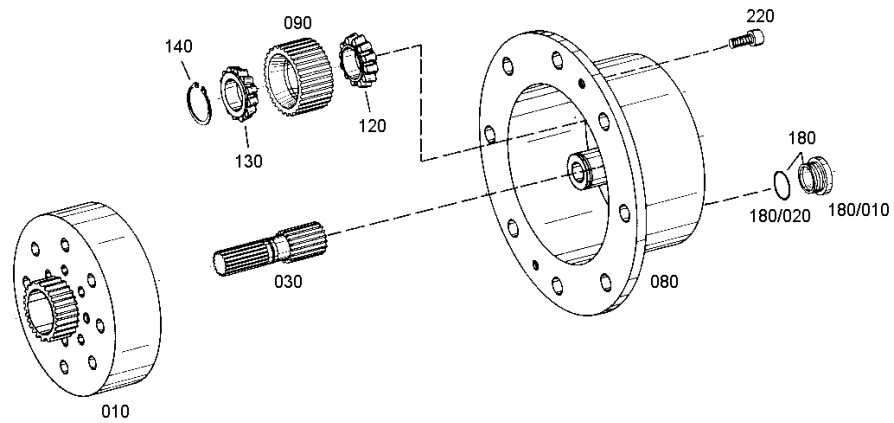

Plant

Page 1 from 1

Material number: 4475.006.052

Plant: 447510500100

Material-assembly-group-no: 4475.105.041



AS 2045 /
STEERING

